

Model 300

0.01 Hz - 30 MHz

Frequency Response Analyzer

ANALYZER SOFTWARE VERSION 3.2

Copyright 2015

Copyright Notice

This manual is copyrighted. All rights reserved. This document may not, in whole or part, be copied, reproduced, reduced or translated by any means, either mechanical or electronic, without prior consent in writing from AP Instruments.

AP Instruments

355 Tesconi Circle, Suite #A, Santa Rosa, CA. 95401

Phone: (707) 544-2170 Fax: (707) 544-5816

Web: <http://www.apinstruments.com>

Federal Communications Requirements

Warning- This equipment generates, uses, and can radiate radio frequency energy and if not installed and used in accordance with the instruction manual, may cause interference to radio communications. It has been tested and found to comply with the limits for a class A computing device pursuant to Subpart J of Part 15 of FCC rules, which are designed to provide reasonable protection against such interference when operated in a commercial environment. Operation of this equipment in residential areas is likely to cause interference in which case the user at his own expense will be required to take whatever measures may be required to correct the interference.

Doc# 000323

The Model 300 Frequency Response Analyzer

The Model 300 Frequency Response Analyzer system is composed of an integrated source/receiver unit, probes, interface cables and software for a user provided Windows based computer.

The Model 300 Frequency Response Analyzer offers the following high performance features

- 0.01 Hertz to 30 Megahertz coverage
- 110 dB's of dynamic range with 0.025 dB mag. and 0.2 degree phase accuracy
- Up to 10,001 measurement points with linear or logarithmic frequency sweeps
- Automatic magnitude and phase correction compensates for test leads or fixtures

Graphical interface features

- Windows® based graphical user interface with real time plotting
- Virtual instrument front panel for complete access to all system parameters
- Automatic or manual scaling and shifting of screen plots for optimum viewing
- Advanced marker functions and master graphs give data and delta readouts.
- Advanced functions including complex impedance

Source features

- Direct digital synthesis for fast sweeps
- 0.01 Hertz to 30 MHz range, 0.01 Hertz resolution
- Output level adjustable from 1.25 millivolts to 7.08 volts rms (20Vpp)
- Selectable 2 ohm or 50 ohm output impedance with 500mA peak output current
- Output can be DC offset up to +/- 10 V eliminating large coupling capacitors at low measurement frequencies
- User programmable variable source level with frequency

Receiver features

- Two channels for B/A ratioed, transfer function measurements
- High selectivity two stage receiver architecture for high noise immunity
- Digital signal processing provides a user selectable IF bandwidth, optimizing noise immunity and measurement speed
- Selectable AC ($\geq 10\text{Hz}$) or DC coupling with one megohm input impedance
- Inputs can be DC offset up to $\pm 8\text{ V}$ facilitating DC coupled measurements

Table Of Contents

Chapter 1 : System Installation	7
Hardware Installation.....	7
Software Installation	9
Chapter 2 : Virtual Front Panel Operation.....	11
Software Overview	11
Graph Display Modes	14
The Graph Window.....	15
The Data Window	17
Menu Selections.....	20
File Menu	20
Edit Menu.....	22
View Menu.....	23
Graph Menu	25
Tools Menu	26
Probe Calibration	38
Toolbars	41
Main Toolbar	41
Sweep Control Toolbar	43
Sweep Frequency Toolbar	45
Source Parameters Toolbar	46
Receiver Parameters Toolbar	48
Graph Tools Toolbar.....	49
Marker Functions Toolbar	51
Chapter 3 : Data Transfer.....	53
Data Files	53
Image Files.....	54
The Clipboard	55
Dynamic Data Exchange (DDE).....	56
Data Links Reference.....	57
Execute Links Reference	61
Using DDE in Microsoft Excel.....	64

Chapter 4 : Application Notes.....	71
Introduction to Analog Network Measurements	71
Basic Measurement Procedures.....	73
High Frequency Measurements.....	75
Circuits with Nonzero DC Voltage Levels at the Input / Output Node.....	76
Measuring Circuits with High Common Mode Voltages	76
Measuring Feedback Loop Frequency Response	77
Measuring Complex Impedance.....	81
Line Current Harmonic Measurements	83
Power Transmission/Reflection Measurements	84
Appendices	87
Appendix A: Theory of Operation	87
Appendix B: Measurement Accuracy	88
Appendix C: Specifications.....	92
Appendix D: File Types; Use and Format.....	95
Appendix E: Default Setup Values.....	98
Appendix F: Repair and Warranty Information	100
Appendix G: AC Power Fuse Replacement	102
Appendix H: System Calibration / Performance Verification.....	103
Quick Performance Test.....	103
Full Performance Tests.....	104
Index.....	113
Safety Notices.....	116

1

System Installation

Hardware Installation

[[Note: Perform software installation prior to powering up the analyzer]]

Host PC requirements for using the Analyzer

Operating System: Windows versions XP, Vista, Windows 7, Windows 8

PC Hardware: 1 GHz processor or faster recommended, USB 2.0/1.1 port. X VGA video card resolution or higher.

- Verify that the local AC mains voltage level matches the setting of the line voltage selector switch on the rear panel. Set the switch as required for the AC mains supply, either 115VAC or 230VAC as appropriate. If the line selector switch was initially in the incorrect position then the fuses will need to be inspected and possibly replaced with the correct values since different fuses are used for 115VAC and 230VAC. See appendix G for instructions on replacing the fuses.
- Using the provided AC power cord connect the cord to the Analyzer's rear panel mains input while plugging the other end of the cord into the AC mains. Turn on the Analyzer's front panel power switch. The green power light should be on. Now turn off the power switch in preparation for the software installation.
- Connect the Analyzer's rear panel USB connector to the host PC's USB port using the provided USB cable.
- Connect the source probe, a 1:1 cable with clips, to the source output BNC. Connect the two input probes, labeled "A" and "B" to their respective BNC's.
- Do not power up the analyzer. Proceed to the next step for installing the software and drivers.

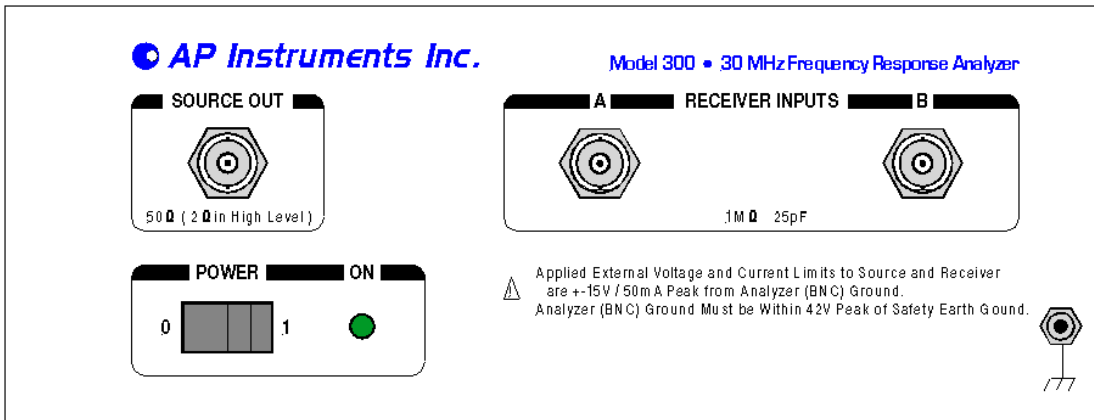

Model 300 Front Panel Showing Source Output BNC, Receiver Input BNC's and the Power Switch

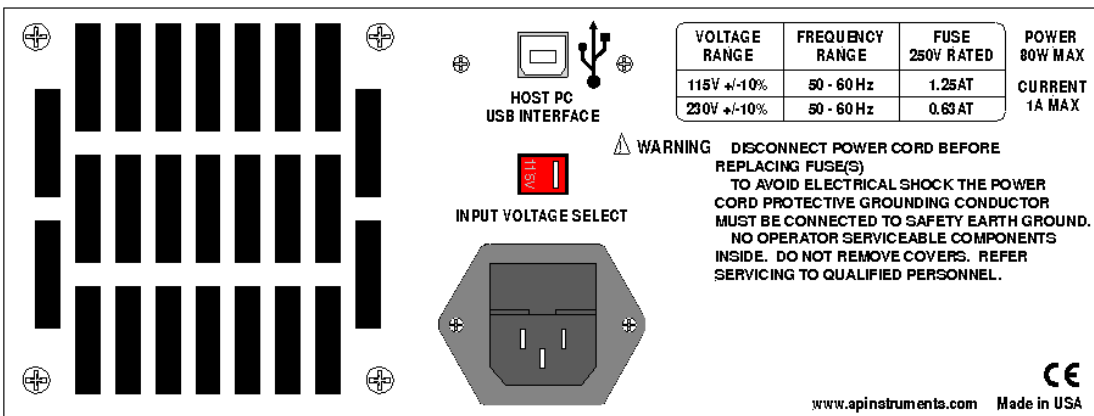

Model 300 Rear Panel Showing USB Connector, AC Mains Voltage Selector Switch and the AC Mains Input

Software Installation

Installing the Windows Software

Make sure the Analyzer's power switch is turned off. Insert the software installation CD media labeled "AP Instruments Windows Software for the Model 300 Frequency Response Analyzer" into the host computers CD drive. The installation should start automatically when the CD is inserted. If it does not start automatically, then while in Windows, use the program manager's RUN command to execute the setup program "x:\setup" where x is the drive letter of the PC's drive where the installation media is located. The setup program will create a directory (default location of C:\AP Instruments) and transfer the required program files to this directory. The setup program will also create a program group called "AP Instruments".

Installing the USB Port Driver

After the installation program installs the graphical user interface software it will automatically start the USB driver install procedure. This procedure first displays a message window followed by the installation of two drivers. The message window pops up prior to driver installation as a reminder that two drivers are installed; click OK to begin driver installation. Be aware, the hardware wizard will execute twice.

NOTE: Installation of the driver may require that the installer be logged on with Administrator privileges.

IMPORTANT: The analyzer will not function without the correct driver installed.

Starting the Software

The Windows analyzer software icon, named APfra, is located within the AP Instruments program group. Before starting the software ensure the hardware is properly configured, the analyzer's power is on and the USB cable is connected between the analyzer the PC. Double clicking on the APfra icon will start the software.

WARNING !

DO NOT ATTEMPT TO MAKE MEASUREMENTS ON HOT OR UNGROUNDED SYSTEMS !!! DO NOT ATTEMPT TO SHIFT THE SOURCE/RECEIVER GROUND BEYOND 42V PEAK FROM HOST PC (EARTH) GROUND OR OPERATOR SAFETY WILL BE COMPROMISED AND EQUIPMENT DAMAGE MAY OCCUR!!!. If it is necessary to make measurements on such systems then use an isolation transformer on the system and ground the system under test to an earth ground. See application notes for high common mode voltage measurement procedures. Working on or around line voltages has electrical shock hazards for both the operator and the instrument that must be understood before measurements are attempted!

IMPORTANT NOTICE !

To allow for proper cooling it is important that the analyzer unit have unobstructed air venting slots. Maintain at least two inches between the Analyzer's rear panel and other objects. Keep the analyzer's bottom air venting slots unobstructed.

2

Virtual Front Panel

Software Overview

The frequency response analyzer software (APfra.exe) program uses a PC based Windows platform to provide a virtual control panel and graphing windows user interface to the frequency response analyzer hardware. The software's user interface offers the following key components :

- A virtual front panel for Instrument control.
- A graphics display which plots the acquired data in a variety of formats, called display modes and provides real-time data analysis through markers and master or reference traces.
- Control over system parameters such as graph colors and data format.
- Data transfer. Measured data is made available to other applications through data files, the clipboard, image files, and Dynamic Data Exchange (DDE).
- Environment persistence. Save and restore all the display attributes and analyzer parameters (including special calibrations) for a particular measurement.
- Working offline provides the convenience of analyzing data files without the analyzer hardware connected.

Selectable Functionality with the Extended Functions Interface

The analyzer software has many features which initially can introduce unwanted complexity. It is for this reason two user interface options are provided, the **Standard** and **Extended** Functions Interface. The standard interface is active by default after installation. This interface has basic control and measurement functionality but excludes many of the advanced features. New and infrequent users are advised to use the standard interface, as most any measurement can be made and the learning curve is greatly reduced.

The extended functions interface is enabled (toggled on and off) using the *View>Extended Functions Interface* menu item. In addition to the standard interface functionality the extended interface includes :

- Selectable number of graph markers up to five, and data analysis marker functions which includes Min, Max, Goto, Find, Tracking and more.
- Sweep data averaging.
- Variable swept source (Power sweep).
- Real-time graph zooming and panning.
- Calibrations for unique probe and cabling configurations.

You may switch between the standard and extended interface at any time but be aware that switching from the extended to standard interface will disable extended functions and therefore reset any extended functions currently in use.

Offline Mode

Using the Analyzer Software Without Operational Hardware

Starting the analyzer software while the analyzer's power is turned off or the USB cable disconnected will display the following dialog box:

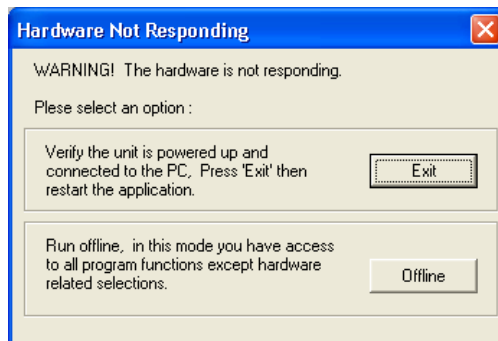

You have the option to exit and correct the hardware connection or continue and execute the software in offline mode. When choosing 'Offline' the software will execute normally except that any menu selections or toolbar buttons which control hardware will be disabled.

All data analysis including master traces, reference traces, markers, and marker functions are available, as well as data transfers such as the clipboard, data, and image files. DDE transfers are not available.

Working offline is useful only when previously stored data files are available.

Use the menu selection *File>Open Data>Open Data...* to load a saved data trace and *File>Open Data>Open Master Data...* to load a data file as the master trace. Data files which do not have an associated ‘raw’ file will have some limitations, See the section on Data Files for more information.

Note: While offline the software will not be able to detect if the analyzer has been subsequently powered on or the USB cable reconnected. You must exit the analyzer software and restart it.

Virtual Instrument Front Panel

The analyzer software program divides the application window into five areas. As shown in the sample below, from the top down, there is the Menu, Parameter Input Toolbars, Graph Window, Data Window, and Status Bar.

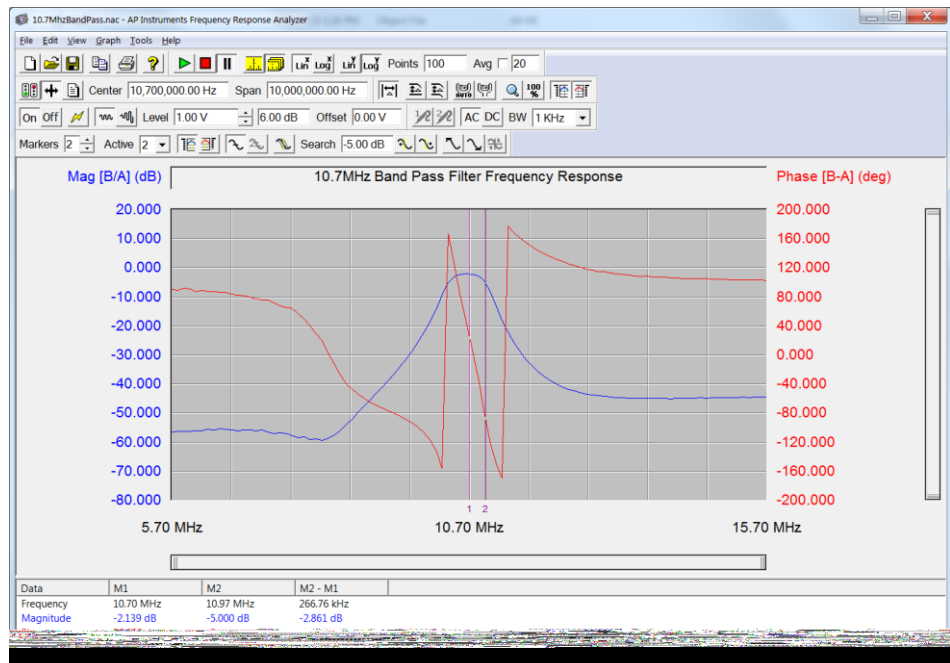

Graph Display Modes

The graph can display the acquired data in one of three basic *Display Modes*. The selectable display modes are Magnitude & Phase, Absolute Mag ch. A & B, and Complex Impedance. The labels above the left and right scaling always display the mode data types with units in parentheses. A particular display mode is selected using the *Graph* menu.

Magnitude and Phase

The first display mode, magnitude and phase, graphs the ratioed measurement of channel B divided by channel A. The magnitude represented is expressed in dB while the phase is expressed in degrees. A positive value of magnitude indicates gain through the network under test (i.e. $B > A$) while a negative value of magnitude indicates attenuation. The phase display range can be chosen through the *Data Format* tab of the *Tools > Options* dialog box to wrap at a selected angle or continuously unwrap (see Data Format Options). The phase shift indicates the relative phase shift from channels A to B. Note that the source level does not enter the equation. The source level does, however, become important for optimizing the signal to noise ratio and preserving the linearity of the network under test.

Absolute Magnitude

The second display mode, measures the absolute magnitude of channels A and B displaying it in RMS volts. This mode is useful for diagnosing a noisy B/A measurement by showing the actual (absolute) signal strength of each channel.

Complex Impedance

The third display mode graphs the complex impedance of a network under test when using an external reference resistor connected to the network in a specific manner (see application note on measuring complex impedance). The reference resistor value is entered as a parameter.

The complex impedance, Z , can be displayed as one of the following :

- Real Z and Imaginary Z
- Magnitude and Phase of Z
- Equivalent Capacitance and Resistance
- Equivalent Inductance and Resistance
- A choice of series or parallel circuit models are available.



The Graph Window



The graph window is the area which displays the measurement data graphically in the traces, this area also contains the graph title and additionally, in the extended interface, the pan / zoom controls.

Within the Graph area use the left mouse button for movement and the right button for popup menus and dialogs. To move an object place the mouse pointer within close proximity then press and hold the left mouse button, release the button to *drop* the object at the desired location. When more than one object is within the mouse selection range the object closest to the mouse will be selected. Clicking the right mouse button will 'popup' either a menu or dialog within the context of the current mouse location. When the mouse is close to a movable object (either Marker or Ref trace) right-clicking will bring up a dialog box for absolute placement of the object. Otherwise right-clicking will popup a menu which provides basic functionality such as toggling Markers, Master, or Reference traces, scaling, and locating Markers and Reference traces.

The recessed box just above the graph is the title area. Click the left mouse button within this box to enter a title for the displayed data, while in edit mode the title box is white. When you are through typing hit the *Enter* or *Tab* key, the text will be displayed centered within the title area.

Real-Time Traces

The graph display window can display two separate real time data traces simultaneously, generally referred to as the left and right trace, distinguishable by their color. The trace colors can be selected by selecting the *Color* tab of the *Tools>Options...* dialog box. The minimum and maximum range of the graphed data can be chosen manually or automatically using the Manual Scale  or Auto Scale  toolbar buttons. The axis scaling for each trace is indicated separately on the left and right ordinates. The format of all numeric data displayed for either the axis scaling or the marker readout can be changed using the *Data Format* tab of the *Tools>Options...* dialog box.

Extended Functions Interface Only: Use the  and  buttons to view/hide the left or right trace, this also hides the left master/reference or right master/reference trace as well. These trace view/hide buttons will not stop any data collection or post processing (such as trace math or averaging), they only serve to hide data which is not of interest.

Master traces

The master trace is a stored data trace available within the graph display. Master traces allow comparisons between a stored trace and the active (real-time) trace. To add master traces to the graph use the  button (or select Master Trace from the graph popup menu). When master traces are selected the current active trace data is copied as the master trace. Note that this button is available only after a complete sweep of real-time data has been acquired. The master trace marker data readout is displayed below the active trace marker data in the Data Window (See The Data Window for information on its use). The delta data readout, displayed to the right of the absolute marker data, gives the difference between the master and the active data trace separately for both left and right traces. Master traces are also used to display the data when a data file is loaded or data is pasted from the clipboard. This allows saved data to be used for future comparisons and go/nogo testing. Note that the reference trace and the master trace cannot be used simultaneously.

Reference traces

The reference trace is a floating horizontal baseline from which relative measurements are made. Use the  button to activate the reference traces. When active, two reference traces appear, a left and right reference trace. The reference value and delta data corresponding to the vertical marker intersection are displayed in the Data Window. Setting the reference value is accomplished by moving the trace with the mouse or typing a value in the 'Set Value' dialog box (right-click on the reference trace to bring up the dialog box).

Important : Reference traces are value fixed, this means that they do not change value when the graph scale changes. Therefore it is possible for a reference trace to lie outside the graph. When this occurs the reference trace is not visible but the Data Window display is still maintained and accurate. To change a reference trace value it must first be visible, do this by either (1) change the scaling, or (2) bring the trace back into view using the Find Reference item from the graph popup menu, the selected trace (either left or right) will be placed at the current mouse position. Note that the reference trace and the master trace cannot be used simultaneously.

Zooming within the Graph Window

The extended interface provides real-time panning and zooming of the graph. Zooming does not alter setup parameters therefore the sweep span and graph scaling do not change, it just provides viewing a smaller area of the graph. It is important to realize that a zoomed area does not increase the real resolution of the collected data, the distance (in frequency) between

data points is determined by the sweep span and number of data points selected. Data between points are linear interpolated and displayed as a line segment.

Zooming is most useful when the examined region contains sufficient resolution for further analysis. The sweep points should be set between 300 and 400 at a minimum, at 800 to 1000 points the traces are quite smooth at maximum magnification.

To narrow in on an area of interest use the Zoom button () located on the *Graph Tools* toolbar, when this button is selected the graph enters 'zoom' mode and the cursor changes to a magnifying glass. While in zoom mode 'zooming in' is accomplished by either of two methods:

- Point centered selection - Click the left mouse button to zoom into an area centered about the selected point.
- Area selection - Position the mouse at the upper-left corner of an area of interest then press and hold the left mouse button to begin the area selection, a 'selection rectangle' will follow the mouse. Move the mouse to the bottom-right corner and release the mouse button. The graph will now zoom to display the selected area.

While zoomed the system behaves normally, nothing has changed, only the area of the graph which is displayed. Zooming out is accomplished by holding down the control key (Ctrl) and clicking the left mouse button, or use the Unzoom button () to view the entire display again.

The 'PanZoom' controls to the right and below the graph provide zoom control as well as visual status of the zoomed area. These controls work very similar to the standard windows scrollbars. Like scrollbars the *handle* is dragged by pressing and holding the left mouse button, but unlike scrollbars dragging the edges (the area with the raised ridges) changes the size of the handle. Moving the handle by selecting at the center provides a 'panning' action. Selecting at an edge provides a 'zoom' action. The position and size of the handle serves as an indicator to the level of magnification and area of the graph displayed.

The Data Window

The data window displays the trace data at marker locations. Note that graph markers must be enabled to activate this window pane. Displayed data includes the marker frequency, real-time trace data, master or reference trace data, delta (real-time – master or real-time – reference) data, and variable source data. This data is arranged with markers running along

the columns and trace data down the rows. The data window is displayed below the graph window and is active only when markers are enabled. The window size is adjusted using the sizing bar located between the graph and data windows, column widths are adjusted by moving the dividers within the column heading.

Finding specific data can become difficult as the number of traces and markers increase due to the sheer volume of data presented. Using the techniques described below to parse and format the data can aid in location and analysis.

The first technique is to hide superfluous data. Using the left and right trace view/hide buttons is the simplest and most effective way to reduce the quantity of data, hiding either trace effectively reduces the data by half. Also, limit the number of markers as necessary. Note : Both of these features (view/hide buttons and selectable marker count) require the extended interface. Lastly, disable reference traces when they are not being used, while enabled they add significantly to amount of displayed data. The Reference trace values are maintained while they are disabled so they are right where you left them next time they are enabled.

The second technique does not remove data but formats it, properly formatted data can aid considerably in its comprehension. Use the *Data Format* Tab on the *Tools>Options...* dialog to properly format the data for your application.

The last technique uses the *Data Columns* tab on the *Tools>Options...* dialog to specify and arrange the columns in the data window. Data window columns display trace data of individual markers and the difference between markers. The column order, individual markers, and marker differences are all definable. This is an advanced technique which has little usefulness when using two markers, the value is realized when making complex measurements with three or more markers.

Markers

Graph markers are used to make measurements at specific frequencies, while markers are enabled the *Data Window* displays the trace data at the marker frequencies. Markers are toggled on and off with the  button and appear as vertical lines with the marker number displayed directly underneath. Setting a marker frequency is accomplished by moving the marker with the mouse or typing a value in the 'Set Frequency' dialog box (right-click on the marker to bring up the dialog box). Data for all visible traces, including master and reference traces, is displayed in the Data Window. The Data Window also displays 'delta marker' (i.e. $M_2 - M_1$) data. See *The Data Window* for more information on its use.

Important : Markers are *value fixed*, this means that they do not change frequency as the display is panned or zoomed, and are independent of the sweep start and stop frequencies.

Therefore it is possible for a marker to lie outside the graph making it impossible to move or set. To bring a marker back into view use one of these two methods:

1. Left click at the extreme edge of the graph, either the left or right side. The closest off-screen marker on that side of the graph, if one exists, will be placed at the current mouse position. Each left-click will in turn 'bring' the next closest marker to the mouse position.

2. Right click and select the 'Find Marker' menu item from the graph popup menu, the selected marker (or All markers) will be placed at the current mouse position.

Extended Functions Interface Only: With the standard interface two markers are available, the extended interface provides a selectable number of markers up to a maximum of five. Also with the extended interface a *Marker Functions* toolbar is available. This toolbar provides functions to search the real-time trace data.

Menu Selections

There are six pull down menus available at the top of the window. The menu choices are represented below.



File Menu

Open Setup...

Opens a dialog box which allows a previously saved configuration to be loaded. All parameters will be set to the new values.

Save Setup

The current configuration file is updated. This updated setup can then be recalled using the Open Setup... command. Only the configuration of the selected display mode is saved. See File Types, Use and Format for more information.

Save Setup As...

Opens a dialog box which allows the current configuration to be saved as a file. This setup can then be recalled using the Open Setup... command. Only the configuration of the selected display mode is saved. See File Types, Use and Format for more information.

Open Data >

Loads a previously saved sweep data file and displays the data as a trace in the graph window. A sub-menu selects to load the data as the main data traces or master data traces. Once loaded, sweep data may be analyzed like measured realtime data.

Save Data >

Saves the current displayed data sweep data as a text file, also saves the primitive data as an associated raw binary file. A sub-menu selects to save the main data or master data to file. Use the *File>Open Data* menu selection to load this saved data back again.

The text data is saved with the extension .dat, the binary data is saved with the .raw extension. See 'Data Files' for additional information and 'File Types, Use and Format' for details of the data (.dat) file format.

Save Graph Image...

Saves the screen image of the analyzer software's graph display window to disk in one of four image formats. See 'Image Files' in the Data Transfer chapter for more information.

Print Graph...

Opens the standard print dialog box. The graph display window is printed using the selected print options. This command behaves differently than the toolbar print button which does not invoke the dialog box.

Print Display Mode Setup...

Prints to the system printer a list of the current analyzer setup parameters.

Print Preview

Displays a preview of the printed page.

Printer Setup...

Opens the standard print setup dialog box.

Exit

Exits the application. Sweep data in memory will be lost unless saved. The present configuration will be lost unless saved.

Edit Menu

Copy Data

Copies sweep data to the clipboard. After executing this command the clipboard will contain the last full sweep, except during the first sweep which will copy only the current collected data. The sweep data will be copied with the same format as in Save Data As... and using the selected phase format. This function is unavailable (grayed) when sweep data memory is empty. This function is also available on the Toolbar.

Copy Master Data

Copies the Master sweep data to the clipboard. After executing this command the clipboard will contain the contents of the master data. The sweep data will be copied with the same format as in Save Data As... and using the selected phase format. This function is unavailable (grayed) when the master trace is not active.

Copy Bitmap

Copies the (graphical) contents of the Graph Window and Data Window to the clipboard. The resulting bitmap can be pasted into a program (i.e. MS Paint) that accepts bitmaps.

Paste Data to Master

Pastes the clipboard data, as previously copied using the Copy Data command, to the Master Trace.

View Menu

Toolbars...

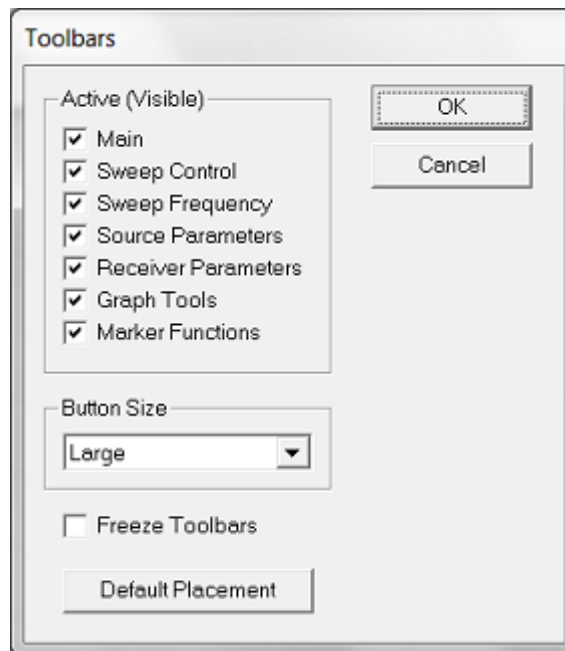

This dialog box gives the option to display or hide, freeze or float, and resize the toolbars. Individual toolbars can be displayed or hidden allowing unused functionality to be removed. The toolbars may be displayed in one of three sizes (small, medium, large) to accommodate specific display devices and equipment configurations. To change the toolbar size use the pulldown list to select the desired size and click the 'OK' button. The software must then be exited and restarted to enable the new toolbar size.

The medium sized toolbars are recommended monitors with resolution of greater than or equal to 1200x900.

The 'Default Placement' button resets the toolbars back to the default configuration. This includes toolbar placement and visibility. The 'freeze' checkbox is also unchecked (toolbars can float). The only setting unaffected is the button size.

Status Bar

In checking this option a status bar at the bottom of the display will be visible. The status bar indicates the display mode the sweep status, the sweep count and a sweep bargraph.

Extended Functions Interface

In checking this option all of the analyzer software functions are available for use on the virtual control panel. If unchecked a reduced set of functions are available for use.

Graph Menu

Magnitude & Phase

Selects the Magnitude and Phase display mode. When this mode is selected the left trace will display magnitude B/A data in decibels and the right trace displays phase B/A data in degrees.

Absolute Magnitude

Selects the Absolute Magnitude display mode. When this mode is selected the left trace will display the absolute magnitude of channel A in volts and the right trace displays the absolute magnitude of channel B in volts.

Complex Impedance...

Selects the Complex Impedance display mode. When this mode is selected the Complex Impedance option in the Tools menu appears allowing complex impedance parameters to be selected. These parameters include :

- | | |
|------------------------|---|
| Topology | - The measurement configuration used. |
| Reference Resistor | - The series resistor to the network under test. |
| Equivalent Circuit | - Model the equivalent circuit as Series or Parallel. |
| Parasitic Compensation | - Mathematically cancels the effects of unwanted series and shunt elements. |

The complex impedance measurement definitions are setup in the Tools menu under Complex impedance.

Tools Menu

Calibration...

Allows a user defined probe correction array to be generated and subsequently assigned to the probe cal toolbar buttons. This feature is used to compensate for the frequency response of probes and cables. This feature is described in detail later in the Tools Menu topic of **Probe Calibration**.

Complex Impedance...

Allows complex impedance parameters to be selected. These parameters include:

- Topology - The measurement configuration used.
- Reference Resistor - The series resistor to the network under test.
- Equivalent Circuit - Model the equivalent circuit as Series or Parallel.
- Parasitic Compensation - Mathematically cancels the effects of unwanted series and shunt elements.

From the dialog box a display view selection is made from the following:

- Complex Impedance (Rect) - Display complex impedance in rectangular coordinates, $Z(f)=X(f)+iY(f)$, the real part (X) on the left and the imaginary part (Y) on the right.
- Complex Impedance (Polar) - Display complex impedance in polar coordinates, $Z(f)=R(f)A(f)$, the magnitude ($R = |Z|$) on the left and the angle (A) on the right.
- Equivalent Circuit (C&R) - Display the capacitive (left trace) and resistive (right trace) components of an equivalent (series / parallel) circuit.
- Equivalent Circuit (C&Dissipation) - Display the capacitive (left trace) and dissipation factor (right trace) components of an equivalent (series / parallel) circuit.

- Equivalent Circuit (L&R) - Display the inductive (left trace) and resistive (right trace) components of an equivalent (series / parallel) circuit.
- Equivalent Circuit (L&Quality) - Display the inductive (left trace) and quality factor (right trace) components of an equivalent (series / parallel) circuit.

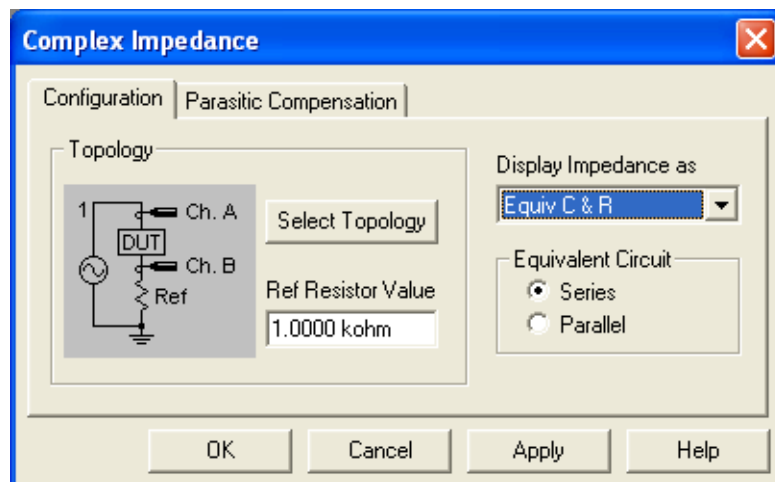

When the 'Select Topology' button is clicked the topology selection dialog is displayed which displays six configurations for Device Under Test (DUT) connections. Choose the topology which matches your setup. The 'Select Topology' and 'Parasitic Compensation' dialogs are shown below.

See the 'Measuring Complex Impedance' application note in the manual for more information on making complex impedance measurements.

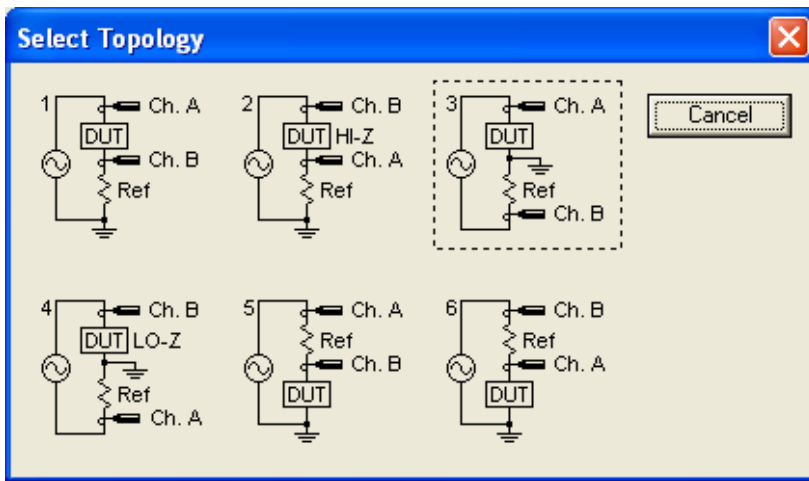

The **Complex Impedance** dialog box has two tabs: **Configuration** and **Parasitic Compensation**. The **Configuration** tab is active, showing input fields for Short Circuit and Open Circuit parameters.

Short Circuit	Open Circuit
Series Elements	Shunt Elements
Resistance	Resistance
<input type="text" value="0.0000e+000"/>	<input type="text" value="1.0000 Gohm"/>
Inductance	Capacitance
<input type="text" value="0.0000 H"/>	<input type="text" value="1.0000 fF"/>

Buttons: **OK**, **Cancel**, **Apply**, **Help**

Variable Source...

The variable or *swept* source is used to vary the source level along the sweep. This operation is also known as a *power* sweep. It is common for the gain of a circuit to vary dramatically along the sweep frequency span, this can compromise measurements when made with a constant source amplitude because no single level will give adequate signal strength without saturating over the entire span. Use the variable source in this situation to increase and decrease the source level as required.

Activate the variable source with the  button from the Source Parameters Toolbar. Upon activation the variable source dialog and the variable source trace appears. The variable source has the following attributes and constraints:

- A series of points define the vertices of the curve (trace). There can be a maximum of 20 points. Each point is defined by a frequency and voltage. The trace is created by ‘connecting the dots’ of vertex points.
- The trace must be defined over the entire frequency range of the instrument. This requires that a point exist at the minimum and maximum frequencies. These two points cannot be removed, the voltage level for these two points are user definable whereas the frequencies are not.
- The voltage level for a point may be any value within the range of the source: 1.25mV to 1.77V RMS (5mV to 7.08V RMS in high source level mode). The voltage between any two points is the linear interpolated value. Note: All voltage values are rounded to the nearest 1dB source attenuator step value.

The Variable Source Dialog

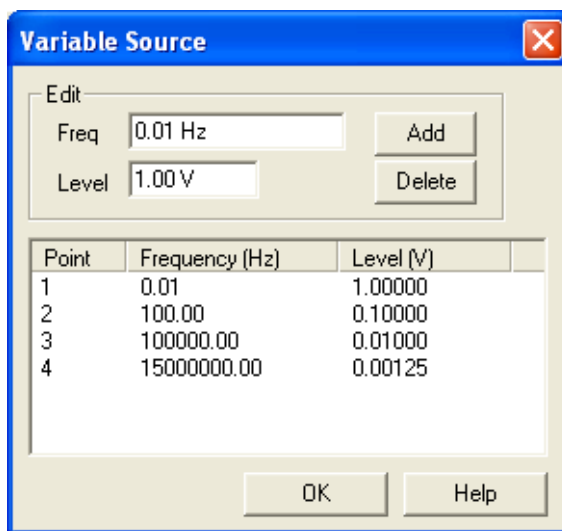

This dialog is divided in two parts, the top (edit) portion is used to add and delete points. Below this is a list of the defined variable source points. To add a point enter a frequency and level and hit the ‘Add’ button. To delete a point first select the point from the list, do this by clicking on the point within the list with the mouse. When a list point is selected its frequency and level is placed into the edit boxes. After selecting the point hit the ‘Delete’ button. It is also possible to change the level of a point by first selecting it, changing the level value, then hitting the ‘Add’ button.

The dialog box can be closed by selecting the ‘OK’ button. Because it is easier to modify the variable source trace directly on the graph (see *Variable Source Trace* below) it is usually unnecessary to keep the variable source dialog active. Once closed, the dialog box can be activated again using the *Tools>Variable Source...* menu item.

Variable Source Trace

The variable source trace provides a graphical representation of the variable source points. This trace identifies defined points by rendering a circle at each point. The variable source trace has its own vertical scaling independent of either the display mode or left and right trace scaling (or zooming). This scaling is logarithmic with min and max voltage levels aligned

with the bottom and top gridline respectively, the grid lines associated with the variable source trace have been omitted to avoid confusion.

This trace is interactive and points may be added, deleted, and moved directly on the graph. To add or delete points right-click the mouse on the trace, this action is context sensitive such that clicking the right mouse button over a vertex point pops up a dialog which allows the point to be deleted, whereas, clicking between points (over a line segment) pops up a dialog which allows a point to be added. Moving a vertex point is accomplished simply by dragging (left mouse button click and hold) the point to a new location. While dragging a vertex point a tool tip appears providing the frequency and level information.

Trace Summing...

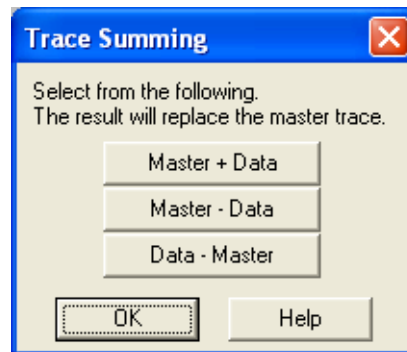

Enables the master trace to be replaced by any one of the following: Master+Data, Master-Data, Data-Master. This feature is useful for summing gains around a feedback loop and for graphically comparing the difference between two traces. The master trace toolbar button must be activated to enable this dialog box.

Options Dialog

The Options dialog is a multi-tabbed window that allows modification of the look and feel of the graph, data, and formatting. This is a 'Modeless' dialog which means that it may be displayed concurrently as, and does not prevent the use of, the main APfra window and its functionality.

Changes in these options can be applied without closing the dialog window, use the 'Apply' button for this. When the 'OK' button is clicked the option changes are applied and the dialog window closes.

The 'Defaults' button on each tab changes the parameter settings on that tab only back to their default values. The 'Apply' or 'OK' must be clicked for these default settings to become active. Choose 'Cancel' to close the dialog and discard changes not yet applied.

Options, Colors tab

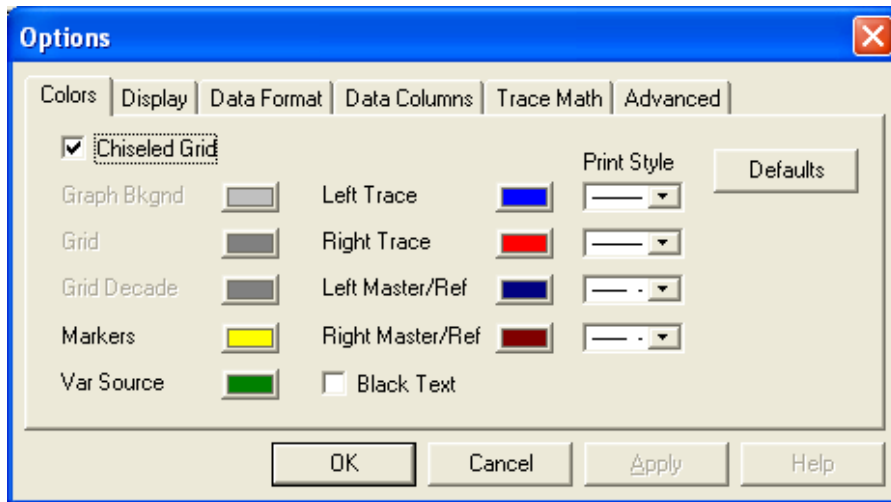

Allows color selections to be made for the various graph display window elements. Printer line style options are assigned here.

Options, Display tab

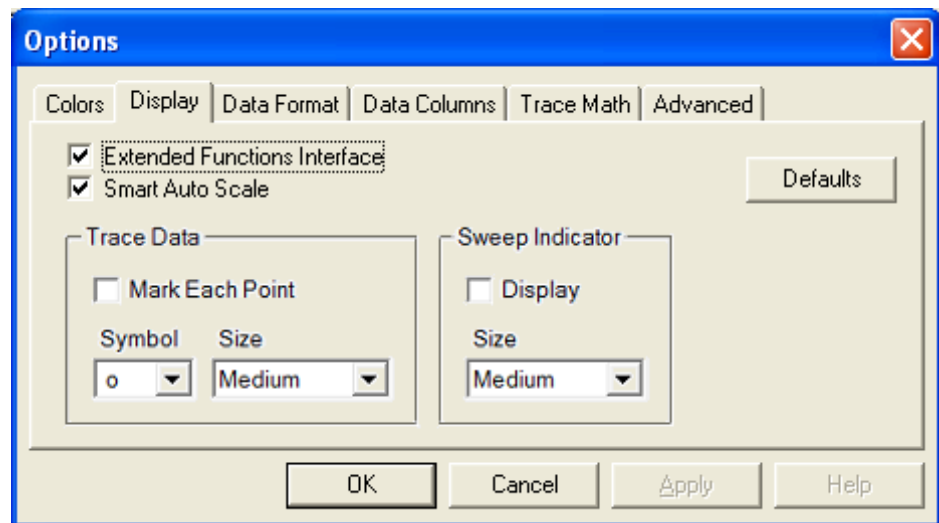

Extended Functions Interface: This enables or disables the extended user interface options as described at the beginning of this chapter. This option can also be found under the 'View' menu.

Smart Auto Scale: When active, the graph display will automatically perform the autoscaling function in some circumstances such as when a graph is first displayed. This option is active by default.

Data Trace Point Marking: When active, each datum of the graph trace will be marked with the specified symbol (choose either 'o', '+', or 'x'). Also, the size of the symbol as either small, medium, or large may be selected. This option is disabled by default.

Sweep Indicator: When 'Display' is checked a small vertical line rides the left and right realtime trace which indicates the current sweep location. The length of this line can be set as small, medium, or large. This option is disabled by default.

Options, Format Data tab

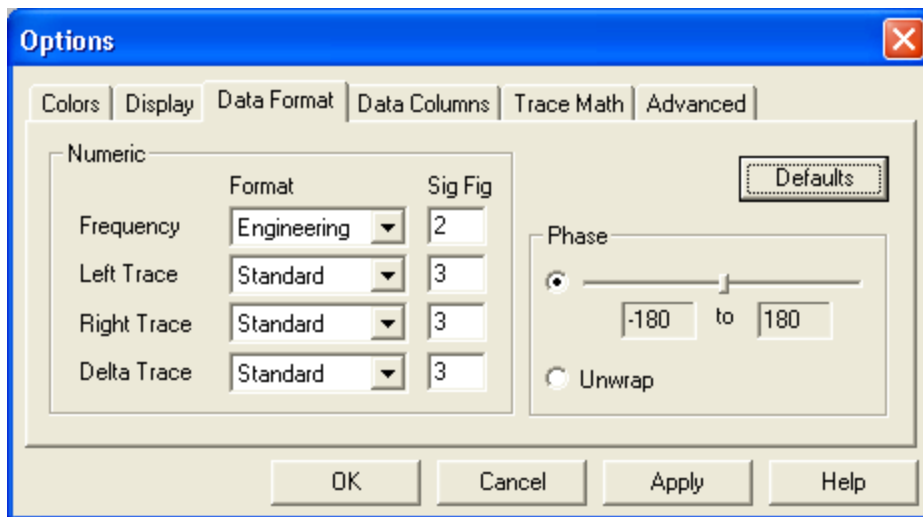

Allows formatting of the data displayed beside and below the graph. Data formatting is independently available for Frequency data, Left trace data, Right trace data, and Delta (Master trace minus the realtime trace) data. The three formatting options are as follows :

- Standard - Numbers are formatted with the standard notation of commas separating every three digits (i.e. 12,456,100.96).
- Exponential - Numbers are formatted in exponential notation (i.e. 1.24 e07)
- Engineering - Numbers are formatted in a scientific notation with the value always between 1 and 1000, a unit modifier is added to represent the decimal position (i.e. 12.45 M).

The number of displayed significant digits is entered in the sigfig edit box. The values above were formatted with sigfig = 2.

The phase option allows the phase data to be displayed either wrapped or unwrapped.

Wrapped - Select the top radio button (next to the slider) to have the phase data wrap at every 2π transition. The transition point may be adjusted using the slider from (-360 to 0) to (0 to 360) in 45 degree steps.

Unwrapped - Select the bottom radio button to unwrap the phase data. The phase is unwrapped by adding or subtracting 2π at phase discontinuities. **Warning:** Phase discontinuities which are multiples of 2π are indistinguishable from a single 2π discontinuity and therefore only 2π is added (or subtracted) at the discontinuity. This can produce inaccurate results with noisy data or large phase changes. In the case of a large phase change increase the number of points per sweep so that no two successive points have a phase difference of more than π .

Options, Data Columns tab

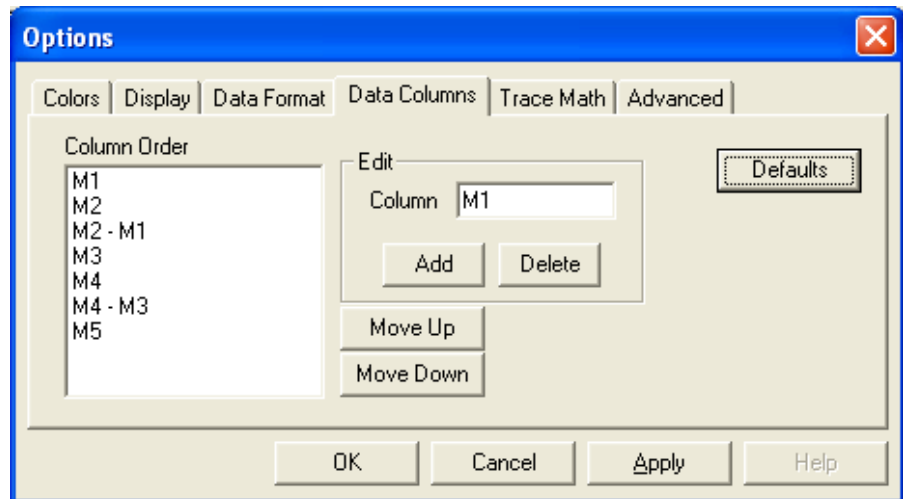

Defines the left to right order of marker data columns as displayed in the Data Window. The topmost item in the 'Column Order' list will be leftmost in the Data Window. Only columns which contain active markers are displayed in the Data Window. To change the column order of a marker (or delta marker) select it in the 'Column Order' list and use the 'Move Up' and 'Move Down' buttons.

When an item is selected it is placed in the Edit Column textbox. It can then be removed using the 'Delete' button. To add a marker (or delta marker) type it into the Edit Column textbox and click 'Add'. The item is added to the bottom of the list where it may be repositioned. Note: Only one instance of a marker can be added, when a marker is added which already exists the marker is selected within the list.

Options, Trace Math tab

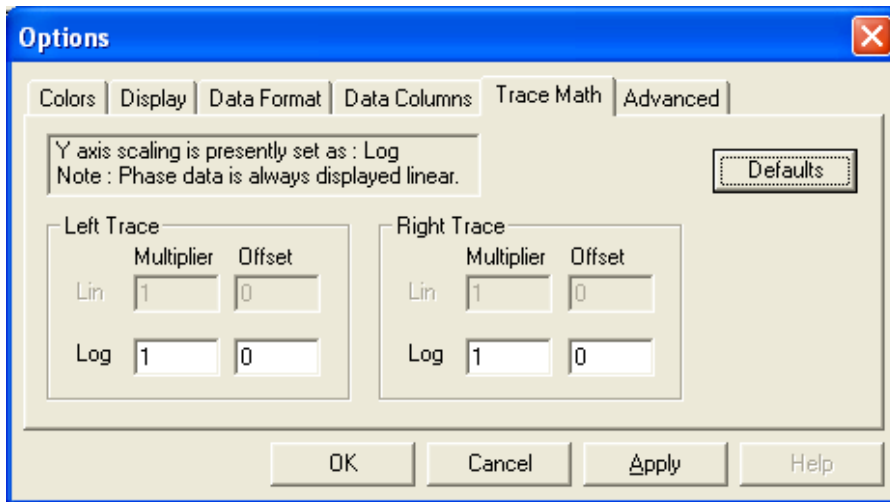

Allows a user defined mathematical multiplier and offset to be applied to the data traces.

Options, Advanced tab

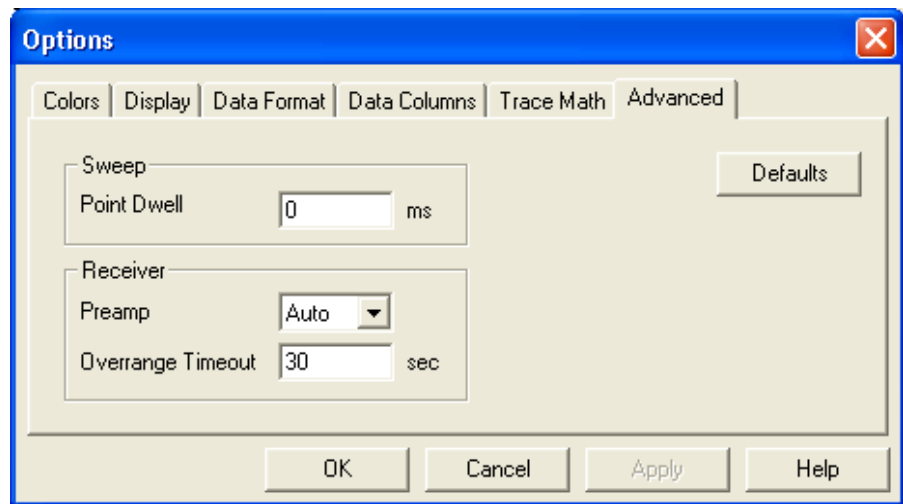

Sweep

Dwell can be adjusted from 0 to 999ms. Normally sweep dwell is left at 0.

Receiver

The receiver Preamp selection allows the automatic preamp gain selection to be overridden. Normally Auto is selected.

When the input voltage to receiver channel A or B exceeds maximum range the analyzer will display a warning dialog. This warning dialog does not block access to the controls so adjustments can be made to correct the over range condition.

The Overrange Timeout is the time (in seconds) that the analyzer will continuously re-sample an over range condition before reacting. The default value is set to 30 seconds, and the range is from 1 to 99999sec. When this time limit is reached the analyzer turns off the source and will pause the sweep in progress.

Probe Calibration

It is generally desirable to have any probes that are connected to the analyzer to have a negligible effect on the measured frequency response of the Device Under Test (DUT). To help achieve this the software allows for a probe calibration so that the frequency response of the probes can be compensated for and nulled out. Note that the probe calibration is not a full system calibration. The system calibration is normally performed on an annual basis as outlined in Appendix H.

Note: Probe Calibrations are only available in the Extended Functions Interface.

The menu item View>Extended Functions Interface will be check marked when the Extended Functions Interface is enabled.

To check the validity of the probe calibration simply connect the source and receiver probes together. The analyzer should give a reading of 0 dB magnitude and 0 degrees phase, within the specified accuracy, across the frequency range.

Probe calibrations are saved as files which are then assigned to toolbar buttons. A calibration is then activated using the assigned button. These three steps of calibration file usage (creation, assignment, and activation) are detailed below.

Creating a Probe Calibration File

Select the menu item Tools>Calibration... to open the calibration dialog.

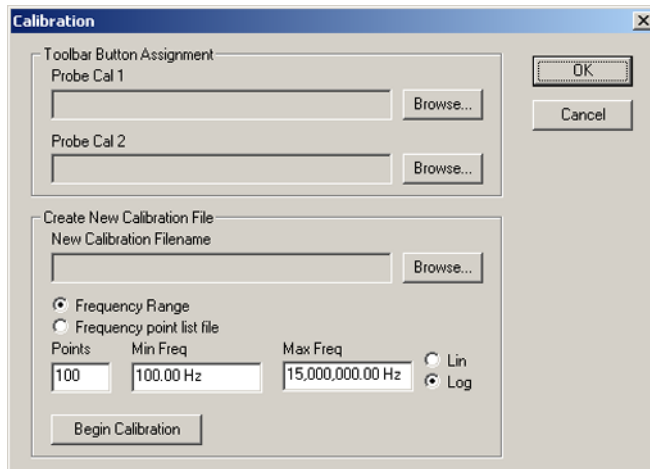

The bottom part of this dialog is used for creating new calibration files. To create a new calibration file perform the following steps

1. Disconnect the analyzer source and receiver probes from the DUT.
2. Connect the Channel A and B probes to the Source Out.
3. Select a file name to store this new calibration. Click the *Browse...* button to the right of the New Calibration File name text box. The Save As dialog will pop up, from here you may navigate to the directory to which to store the calibration file, the 'APfra\Cal' directory is selected by default. Type in the file name in the 'File name:' text box, you do not need to type in the extension, it will be appended automatically. Then click the Save button, you should see the full path name appear in the New Calibration File name text box.
4. Select either a Frequency Range or Frequency point list file (see appendix D for more on frequency point list files). The default selection is a frequency range of 100Hz to 30MHz using 100 points separated logarithmically. You may change any of these settings or choose a frequency point list (FPL) file. An FPL file of the file name 'DefaultCal.fpl' was placed in the APfra\Cal directory during installation, this FPL file contains the frequency points used during factory calibration.
5. Select the 'Begin Calibration' button. A reminder to connect the probes is displayed, if not already done so connect the probes/cables then click OK. Upon completion the calibration file will be generated.

Assigning a Probe Calibration File to a Toolbar Button

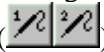
The top portion of the calibration dialog is used to assign calibration files to the two *Probe Cal* buttons on the Receiver Parameters Toolbar (). Click the *Browse* button to the right of the text boxes to assign a calibration file to either the 'Probe Cal 1' or 'Probe Cal 2' buttons. Two Probe Cal buttons have been provided to allow for possible probe/fixture configuration differences. Select OK to close the dialog when complete.

You will notice that the Toolbar Probe Cal buttons which have been assigned are no longer disabled (grayed). Also when the mouse positioned over a button and held momentarily a tool tip pops up which displays the calibration file name assigned to that button.

These assignments are saved as part of the setup configuration and will therefore be available anytime the setup is opened. See *Open Setup...*, *Save Setup*, and *Save Setup As...* File Menu options for more information on configuration setup files.

Activating a Probe Calibration File

To activate (use) a calibration file click the toolbar button to which it has been assigned. When active, the toolbar button will be pressed and the fourth status indicator box of the status bar (at the bottom of the window) will display either 'PrbCal1' or 'PrbCal2'.



Only one Probe Cal can be active at a time therefore selecting one will disable the other if it was active. To deactivate a calibration file click the toolbar button again, the status indicator will be empty when no calibration files are active.

Note: Probe Calibrations are only available in the Extended Functions Interface.

The menu item View>Extended Functions Interface will be check marked when the Extended Functions Interface is enabled.

Toolbars

Nearly all functions relating to the operation of the Frequency Response Analyzer are available on the seven toolbars. The *View>Toolbars...* menu selection provides various toolbar customizations such as toolbar size, exposed functionality, and individual toolbar visibility.

Most toolbars have advanced functionality which is unavailable (hidden) by default. This provides a simplified and uncluttered interface of the most commonly used instrument parameters. Full toolbar functionality is enabled by selecting the 'Extended Functions Interface' from the *View* menu.

Toolbars may be displayed in one of three sizes (small, medium, large) to accommodate specific display devices. Toolbars may also be individually hidden, repositioned, and docked or floating. This flexibility, along with standard or extended functionality, provides a personally customized instrument interface.

All instrument parameters take effect immediately as they are selected. The exception to this are the edit boxes which include start & stop frequency, sweep points, averaging factor, user dwell value, source output level & DC offset. These edit boxes have their values updated by hitting the Carriage Return (Enter) or Tab key.

Main Toolbar



New Setup

Loads default parameters into the analyzer virtual control panel replacing those in the previous configuration.

Open Setup

Loads the selected setup file into the analyzer virtual control panel replacing those in the previous configuration.

 **Save Setup**

The current configuration file is updated. This updated setup can then be recalled using the Open Setup... command. Only the configuration of the selected display mode is saved. See File Types, Use and Format for more information.

 **Copy Data**

Copies sweep data to the Windows clipboard. After executing this command the clipboard will contain the last full sweep, except during the first sweep which will copy only the current collected data. This function is unavailable (grayed) when sweep data memory is empty. This function is also available from the edit menu.

 **Print**

Prints the graph display window on the default printer in landscape orientation. In order to print using alternate options use the print command from the file menu.

 **Help**

Executes the help. This function is also available from the help menu.

Sweep Control Toolbar

Standard:



Extended:



Start Sweep

Begins a sweep using the set parameters.

Stop Sweep

Terminates the sweep in progress. Sweep data is not accessible until a complete sweep is finished.

Pause Sweep

Pauses the sweep in progress. A second actuation of the pause sweep button restarts the sweep. Actuating the stop sweep button while paused will reset the sweep.

Sweep Mode

If Single sweeps are enabled then the sweep activity is suspended upon collection of the last data point. A new single sweep is started by clicking the start sweep toolbar button or sweep menu option. If Continuous is selected then the sweeps are repeated continuously.

Sweep Type

If Lin x is enabled then the frequency increment between data points remains constant. The Log x sweep mode gives a frequency increment between points that is logarithmically increasing with frequency thus compressing the frequency axis. Use the Log x selection for

Bode type plots. This parameter is not used when sweeping with a frequency points list file. The increment between each point is solely determined by each frequency point value.



Y Axis Graphing Type

If Lin y is enabled then the units are displayed formatted for linear units. If Log y is enabled then the units (except phase) are displayed formatted for logarithmic units. Use the Log y selection for Bode type plots.

Points

Enter the number of data points to collect. The maximum number of points is 10,001. Available RAM may limit the number of points you can use. Roughly, 25K per 100 points are required. This parameter is not used when sweeping with a frequency points list file. The number of data points will be equal to the number of frequency values in the file.

Avg (Averaging)

Sweep averaging is toggled on and off by clicking the Avg checkbox. The Averaging Factor specifies the weighting of each sweep into the displayed trace, is a value from 1 to 999, entered into the Avg edit box. The weighting of a sweep (weighting factor) is $1 / \text{Averaging factor}$. When enabled, the averaging function averages each sweep into the trace with a weighting factor equal to the sweep count, until the Averaging Factor is reached. When the specified averaging factor is reached, the trace is updated with each sweep weighted by the Averaging Factor.

Sweep Frequency Toolbar

Standard:



Extended:



Sweep frequency limits may be entered as Start/Stop, Center/Span, or File list values.

Start/Stop

Two edit boxes allow for sweep start and stop frequencies to be entered. Frequency values may be entered as standard values, with or without separating commas (i.e. 100.2 or 1,200), exponential values (i.e. 1.2e5), or with one of three standard SI prefixes : m-milli, k-kilo, M-mega (i.e. 1k, 2.6M). After typing a new frequency value you must enter it by hitting the Carriage Return (Enter) or Tab key. Regardless of how the value was entered it will be converted to the comma separated format.

In the event the frequency value entered causes an error (value out of range or start frequency greater than stop frequency) a message box will be displayed and either value may be edited to remove the error.

Center/Span

Two edit boxes allow for the sweep range to be entered as a center frequency and a total span. Frequency values are entered exactly as described in Start/Stop above.

File List

When File list is selected, a frequency point list (.fpl) file is used as the sweep frequency points. The file name is entered into the corresponding edit box either manually or selected through the Browse dialog box.

Source Parameters Toolbar

Standard:

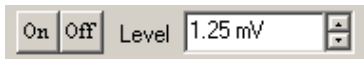

Extended:

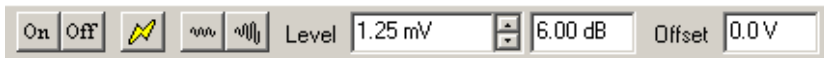

Output

If On then the AC output is set by the level established in the Level edit box. If Off then the AC output from the source is set to zero regardless of source Level setting. The DC source offset is not affected. The output must be off when measuring signals generated from an external source.

High Source Level Mode

When enabled, the Analyzer is placed in a high source level mode which allows greater source output levels and lower output impedance. When the source level mode is in normal mode, i.e. high source level mode is disabled, the Analyzer has a maximum source output level of 1.77V RMS with an output impedance of 50 ohms. When high source level mode is enabled the maximum output level is 7.08 V RMS (20Vpp) with an output impedance of approximately 2 ohms, Note that the receiver inputs have a limit of 1.77V RMS. The high source level mode is intended for circuits that have a low driven impedance and a high source attenuation.

Constant Source Level

Selecting the constant source level will keep the AC source level constant with frequency.

Variable Source Level

Selecting the variable or swept source will allow the AC source level source to vary as a function of the sweep frequency. Upon activation the variable source dialog and the variable source trace appears for editing.

Level

The source output level entry ranges from 1.25 mV to 1.77 V RMS (5 mV to 7.08 V RMS in high source level mode). This source value is associated with the constant source level mode only. There are 64 discrete levels available in 1 dB increments. The level may be typed in directly or increased / decreased in user definable dB steps. Note: When the level is typed in directly use the Carriage Return (Enter) or Tab key to enter the new value. When using the inc / dec buttons the source level will be updated automatically.

Source DC Offset

The Source DC offset entry has a range of +/- 10 Volts DC with a resolution of 0.01 Volts DC. The new DC offset will be entered after hitting the Carriage Return (Enter) or Tab key.

Receiver Parameters Toolbar

Standard:

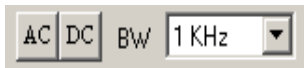

Extended:

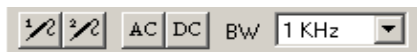

Probe Cal 1,2

When selected a user defined probe correction array is used to compensate for the frequency response of probes and cables. Note that this button is grayed out until a probe calibration file is assigned using the probe cal 1 toolbar button assignment as found in the Probe Calibration Dialog Box. See the section on probe calibration for more information.



Coupling

If AC is selected the analyzer uses its internal coupling capacitors. AC coupling can only be used for sweep frequencies ≥ 10 Hz. If DC coupling is selected then automatic DC offset tracking is employed for inputs up to ± 8 VDC.

BW (BandWidth)

The higher, or wider, the IF bandwidth the faster the sweep will take place. The lower, or narrower the IF bandwidth the better the noise immunity. The noise floor will change approximately 10 dB with each setting. Choose the highest bandwidth that gives a trace with acceptable noise levels.

Graph Tools Toolbar

Standard:



Extended:



Markers

Toggles graph markers. When enabled, the markers and data window are visible. Markers are positioned by dragging them using the left mouse button. The marker data is displayed below the graph within the Data Window.

Reference Trace

Toggles reference traces. Reference traces are horizontal lines which can be set to any value and are used to obtain relative data. When enabled, additional rows appear in the data window which display the reference trace data and the difference (Delta) between the data and reference trace, that is, the Data Trace - Reference Trace. Note: Reference and Master traces cannot be displayed simultaneously.

Master Trace

Toggles master traces. At the moment this is enabled, the data traces are copied and displayed as master traces. When markers are enabled additional rows appear in the data window which display the master trace data and the difference (Delta) between the data and master trace, that is, the Data Trace - Master Trace. Note: Master and Reference traces cannot be displayed simultaneously.

Auto Scale

Executes an automatic scaling procedure on both the left and right trace, then re-displays the graph. Only the realtime trace data is used for autoscaling, Thus it is possible that master trace data may lie outside the graph after auto Scale.



Manual Scale...

Opens the manual scale dialog box in which graph scaling for the left and right trace is accomplished. When this dialog box opens, the current minimum and maximum values are displayed



Zoom

Toggles zoom mode. When enabled (and the mouse is within the graph area) the cursor changes to a magnifying glass which defines the new start, stop frequencies and the new upper, lower graph limits.



UnZoom

Restores the display to view the graph as the limits existed before the Zoom command was activated.



Display Left Trace

This button controls the visibility of the left trace. By default the trace is visible (button pressed). While hidden, all left trace data, including reference or master trace data are hidden, and all rows within the data window corresponding to this data are removed. Hiding data does not in any way inhibit processing (i.e. averaging, trace math, etc.), it only removes the data from view.



Display Right Trace

This button controls the visibility of the right trace. By default the trace is visible (button pressed). While hidden, all right trace data, including reference or master trace data are hidden, and all rows within the data window corresponding to this data are removed. Hiding data does not in any way inhibit processing (i.e. averaging, trace math, etc.), it only removes the data from view.

Marker Functions Toolbar



Note: Toolbar active in the Extended Functions Interface only.

Markers in Use Select Box

The up/down arrows allow from 1 to 5 markers to be displayed.

Marker Active Selection Box

Chooses which marker (marker 1 to marker 5) is to be used as the active marker for the advanced marker functions.



Search Left Data, Right Data

Depending on the button selected specifies the left or right data trace to be used as the data trace source for the marker search functions.



Search Absolute

The value in the search value edit box is to be used as the search value by the search left/right commands. Active marker will attempt to find the absolute value listed in the search value edit box in the specified data trace.



Search Relative

The value in the search value edit box is to be used as the search value by the search left/right commands. The active marker will attempt to find the relative value listed in the search value edit box in the specified data trace. The relative value is based on the reference trace value which must be active for this function to be ungreyed.



Marker Tracking

With the search left or search right button selected the active marker will attempt to track the value in the search value edit box. The marker frequency becomes the variable so that the value in the search value edit box can be tracked.

Search Value Edit Box

A user defined quantity is entered and used for the marker search functions.



Search Left of Marker, Right of Marker

Will search, and located the active marker, at the marker's left or right. The absolute or relative value as listed in the search value edit box is the search value. The left data trace or right data trace to be searched is selected with the Search Left Data, Right Data toolbar buttons.



Find Max, Min

Searching the specified data trace the active marker will locate the maximum or minimum value.



Reference to Marker

The reference trace is relocated to the current value of the active marker in the specified data trace. The reference trace must be active for this function to be ungreyed.

3

Data Transfer

Data Transfer Options

The frequency response analyzer software (APfra.exe) provides several techniques for transferring data to and from other applications.

- Data files can be saved and imported into other programs or loaded back into the software for future comparisons. Also, since the data file format is a simple text file it is possible to reformat data from other programs (simulation software for example) so it may be opened by the analyzer software.
- The screen image of the analyzer software's application window may be saved to disk and imported into other programs.
- The Windows clipboard can be used to copy and paste data to other programs such as Excel. The analyzer software can also copy to the clipboard a bitmap image of the display area which is useful documentation or presentation (i.e. pasting into Word or PowerPoint).
- Additionally, the analyzer software is a Dynamic Data Exchange (DDE) server. This is a powerful feature which allows the analyzer software to be controlled by, and send data to, any DDE client program in real time. A sample Excel spreadsheet (APfra Dde Demo 300.xls) is provided which demonstrates the DDE functionality.

Data files

Trace data of either the real-time or master trace can be saved as a text file using the *File>Save Data>Save [Master] Data As...* menu commands. The data is saved with the extension .dat. A secondary binary file with the same filename but with the '.raw' extension is also created, this is used by the software when data files are read back (Opened) and otherwise is not user consumable.

The data file (.dat) is a text file formatted with a single line column header followed by one line per data point. On each line are three tab separated values ordered as

Frequency, Left data value, and Right data value. The left and right data values are the data of the selected display mode. This is a useful flat file format which may be viewed using any word processor, or imported directly into Excel as well as a number of other applications.

Data files are read back using the *File>Open Data* menu items. Use the menu selection *File>Open Data>Open Data...* to load a saved data trace and *File>Open Data>Open Master Data...* to load a data file as the master trace. Only data (.dat) files can be selected for loading, however when an associated raw file exists it will be loaded also.

Data files may be loaded with or without an associated raw file but data files loaded without a raw file are limited to the original display mode and display formatting options. When a raw file is loaded with the data file the software has available the primitive data and can therefore perform the necessary calculations to format the data to virtually any display settings (one notable exception is switching between the 'X' axis lin/log setting).

Data files are analyzed prior to loading and a dialog box provides the option to configure the system to best view the data, select the parameter change checkbox at the bottom of the dialog box to make the setup changes. Note: Parameter changes are required when loading data as primary data traces therefore the checkbox will be selected and disabled.

The display mode will always change to that of the saved data. Note: There is no guarantee that the newly loaded trace data will be visible if the parameter change checkbox is not selected since this data may lie outside the current frequency span and/or scaling.

Image Files

The screen image of the analyzer software's application window may be saved to disk in any one of four industry standard image formats. These images may be then imported into applications such as word processors, image editors and presentation software.

To save the display to an image file select the menu command *File>Save Graph Image...* When the 'Save As' dialog appears choose the destination location, type a

file name and select the format of the image file. The image may be saved as a bitmap (.bmp), JPEG (.jpg), PNG (.png), or GIF (.gif) file. If you are not sure which format to use try saving in the JPEG format as nearly all software applications which import images support the JPEG format.

The Clipboard (text data)

Trace data can be copied to the clipboard and therefore available for pasting into other applications. The menu commands *Edit>Copy Data* and *Edit>Copy Master Data* copies trace data to the clipboard as text. The data is formatted as one line per data point, on each line are three tab separated values ordered as Frequency, Left data value, and Right data value. This format is exactly the same as *Data Files* (above) except the column headers are absent.

Clipboard text data may also paste into the analyzer software as master trace data using *Edit>Paste Data to Master*. This capability allows data from other sources to be used in analysis. The data may come from a simulation or post processing of earlier measured data. The clipboard data must be in the same text form as that of the Copy Data command; one line per point with each line containing three tab separated numbers representing Frequency, Left data, and Right data, in that order. If the data format is incorrect and the data cannot be successfully converted into master trace data then the command will abort without warning. Important: Master traces are static data and are not bound by system setup parameters (start/stop frequencies, etc.) therefore it is possible to paste data outside the defined view area in either the X (frequency) or Y direction.

The Clipboard (bitmap data)

Selecting the *Edit>Copy Bitmap* menu item places a bitmap image of the displayed Graph and Marker Data windows onto the clipboard. The bitmap is exactly a screen image of the analyzer software's application window between the toolbars and status bar, thus the size of the bitmap can be controlled by sizing the window.

Dynamic Data Exchange (DDE)

Dynamic Data Exchange (DDE) is a protocol which allows Windows applications to communicate with one another. A *DDE server* is an application which can provide data to other applications through the Windows dynamic data exchange protocol. A *DDE client* is an application receiving data from a DDE server through a DDE link. A *DDE link* is a communications channel between a client and server. A DDE link is established by the client.

A DDE server can provide data to one or more DDE clients through DDE links. Clients establish a communication (link) with a server in the form of a request for information. Once this link is made the server will update the client with the requested information. There are two types of DDE links, Hot and Cold, The hot link is most common (and most useful). A *DDE Hot link* is a DDE link where, once established, the server will notify the client as data changes. The client is not required to initiate any other DDE communications. The server notifications will continue until the link is terminated by the client, or the server application exits. A *DDE cold link* is a DDE link in which data is sent by the server in response to a client request, then the link is terminated. The client must initiate a request (link) each time data is needed.

How a DDE Link is Established

A client will begin requesting data by sending the server three pieces of information which describe the needed data. This information is the *Service name*, *Topic name* and *Item name*. In general, a server can have many services with each service having several topics and each topic handling several items. A client needs to know what services, topics and items the server provides. Each client has its own technique (syntax) for requesting this information, refer to your DDE client application software owner's manual for this syntax information.

The DDE Client

For the most part DDE is used as a means for one application (client) to receive real-time data from another application (server). In some cases the server allows the client to execute a command. This is accomplished as with a link, The client will send a *service*, *topic* and *item* for the command the server is to execute. After receiving the

request the server will execute the command. Also, as with links, the client needs to be aware of what services, topics and items are available for execution.

The Analyzer Software

The analyzer software (APfra) is a DDE server which supports access to the core parameters for frequency response analyzer control and data collection. Higher level APfra post processing (such as averaging and trace math) and data analysis (such as markers and marker functions) are not supported.

APfra supports only one service. All DDE link and execute conversations use the service name of APFRA (note that this is case sensitive).

Links:

The analyzer software, APfra.exe, data links are listed next. Each link is listed as follows:

SERVICE / TOPIC / ITEM (Note: These values are case sensitive.)

Returns: The value(s) this link returns.

Format: The numeric format of the returned value (Note: All **values are returned as text data.**)

APFRA / DATA / FREQ

Returns: The frequency value for all points of a sweep.

Format: An array of numbers (doubles as text) separated by a <CR/LF> (0x0D 0x0A). The size of the array is defined by the value of APFRA / SYSTEM / POINTS.

APFRA / DATA / LDATA

Returns: The left side data values for all points of a sweep.

Format: An array of numbers (doubles as text) separated by a <CR/LF> (0x0D 0x0A). The size of the array is defined by the value of APFRA / SYSTEM / POINTS.

APFRA / DATA / RDATA

Returns: The right side data values for all points of a sweep.

Format: An array of numbers (doubles as text) separated by a <CR/LF> (0x0D 0x0A). The size of the array is defined by the value of APFRA / SYSTEM / POINTS.

APFRA / DATA / ERROR

Returns: The number of data points in error for a sweep.

Format: A single number. (Integer as text).

APFRA / SYSTEM / FREQSTART

Returns: The sweep start frequency.

Format: A single number. (double as text).

APFRA / SYSTEM / FREQSTOP

Returns: The sweep stop frequency.

Format: A single number. (double as text).

APFRA / SYSTEM / POINTS

Returns: The number of sweep points.

Format: A single number. (Integer as text).

APFRA / SYSTEM / XAXIS

Returns: The X axis Lin/Log selection. 0 = Linear, 1 = Log.

Format: A single number. (Integer as text).

APFRA / SYSTEM / YAXIS

Returns: The Y axis Lin/Log selection. 0 = Linear, 1 = Log.

Format: A single number. (Integer as text).

APFRA / SYSTEM / SRCOUTPUT

Returns: The source output state. 0 = Off, 1 = On.

Format: A single number. (Integer as text).

APFRA / SYSTEM / SRCLEVEL

Returns: The constant source level value.

Format: A single number. (double as text).

APFRA / SYSTEM / SRCHILEVEL

Returns: The source level mode state. 0 = Off (standard), 1 = On (high).

Format: A single number. (Integer as text).

APFRA / SYSTEM / SRCDCOFFSET

Returns: The source DC offset value.

Format: A single number. (double as text).

APFRA / SYSTEM / SRCUSE

Returns: The source usage mode. 0 = Constant level, 1 = Variable source curve.

Format: A single number. (Integer as text).

APFRA / SYSTEM / RCVRCOUPLE

Returns: The receiver coupling. 0 = AC, 1 = DC.

Format: A single number. (Integer as text).

APFRA / SYSTEM / RCVRBW

Returns: The receiver bandwidth. 0 = 1Hz, 1 = 3Hz, 2 = 10Hz, 3 = 30Hz, 4 = 100 Hz, 5 = 300Hz, 6 = 1kHz

Format: A single number. (Integer as text).

APFRA / CONTROL / DISPLAYMODE

Returns: The selected display mode and submode if applicable. LSNibble = DisplayMode, 2nd LSNibble = SubMode. See the execute topic DISPLAYMODE (below) for details of the DisplayMode and SubMode bit patterns and Note (1) below for additional information.

Format: A single number. (Integer as text).

APFRA / CONTROL / SWEEPSTATE

Returns: The current sweep status. 0 = Start, 1 = Stop, 2 = Pause.

Format: A single number. (Integer as text).

APFRA / CONTROL / SWEEPMETHOD

Returns: The sweep running mode. 0 = Single sweep, 1 = Continuous sweeps.

Format: A single number. (Integer as text).

APFRA / STATUS / EXECERROR

Returns: A set of flags which provide completion status of DDE execute commands. This link is established to monitor and verify parameters are set successfully when specified through DDE using the execute commands. A flag is set when an error occurred with a parameter of an execute command. The flag is reset when a parameter is within accepted limits. The flags are as follows:

Execute Command	Bit Position
SETUPLOAD	0x00000001
FREQSTART	0x00000008
FREQSTOP	0x00000010
POINTS	0x00000020
XAXIS	0x00000040
YAXIS	0x00000080
SRCOUTPUT	0x00000100
SRCLEVEL	0x00000200
SRCDCOFFSET	0x00000400
SRCUSE	0x00000800
RCVRCOUPLE	0x00001000
RCVRBW	0x00002000
DISPLAYMODE	0x00004000
SWEEPSTATE	0x00008000
SWEEPMETHOD	0x00010000
SRCHILEVEL	0x00040000

Format: A single number. (Integer as text).

Executes:

The APfra execute links are listed next. Each link is listed as follows:

SERVICE / TOPIC / [ITEM] (Note: These values are case sensitive.)

Note : The brackets [] are required for execute ITEMS.

Description of execute command and [ITEM] boundary limits.

APFRA / SETUPLOAD / [DEFAULT]

The equivalent to the File>New menu command.

APFRA / SETUPLOAD / [*filename.ext*]

File name of a setup file to load, extension must be included.

APFRA / FREQSTART / [*float value*]

Set the sweep frequency start value. (0.01 <= value <= 30.0e6)

APFRA / FREQSTOP / [*float value*]

Set the sweep frequency stop value. (0.01 <= value <= 30.0e6)

APFRA / POINTS / [*integer value*]

Set the number sweep points. (2 <= value <= 10001)

APFRA / XAXIS / [*integer value*]

Set the X (freq) axis Lin/Log selection. (0 = Linear, 1 = Log.)

APFRA / YAXIS / [*integer value*]

Set the Y axis Lin/Log selection. (0 = Linear, 1 = Log.)

APFRA / SRCOUTPUT / [*integer value*]

Turn the source on and off. (0 = Off, 1 = On.)

APFRA / SRCLEVEL / [*float value*]

Set the constant source level value (0.00125 <= value <= 1.77)
(high level mode: 0.005 <= value <= 7.08)

APFRA / SRCHILEVEL / [*integer value*]

Set the source level mode to high. (0 = Off, 1 = On.)

APFRA / SRCDCOFFSET / [*float value*]

Set the source DC offset value (-10.0 <= value <= 10.0)

APFRA / SRCUSE / [*integer value*]

Set Constant level or variable source selection. (0 = Constant level, 1 = Variable source curve.)

APFRA / RCVRCOUPLE / [*integer value*]

Set receiver coupling. (0 = AC, 1 = DC)

APFRA / RCVRBW / [*integer value*]

Set receiver bandwidth (0 = 1Hz, 1 = 3Hz, 2 = 10Hz, 3 = 30Hz, 4 = 100 Hz, 5 = 300Hz, 6 = 1kHz)

APFRA / DISPLAYMODE / [*integer value*]

Set the display mode and sub mode. Display mode and Sub mode selections cannot be sent in a single DISPLAYMODE execute command. The Display mode is selected first and then issue a second execute to select a Sub mode. Only the Complex Impedance display mode has submodes. See Note (1) below for more information.

For display modes issue this command with the value of

0 = Mag/Phase, 1 = AbsMag, 2 = CmplxImped.

While in the CmplxImped display mode, change sub modes by issuing this command with the value of

16 = Rect, 17 = Polar, 18 = CR, 19 = CD, 20 = LR, 21 = LQ.

APFRA / SWEEPSTATE / [*integer value*]

Set the sweep running status. (0 = Start, 1 = Stop, 2 = Pause)

APFRA / SWEEPMETHOD / [*integer value*]

Set the sweep running mode. (0 = Single sweep, 1 = Continuous sweeps)

Notes :

1. Clarification of DISPLAYMODE. When changing display modes via DDE (execute command) each execute may be a DisplayMode or a SubMode, but not both. To change the DisplayMode set the LSN to the proper value. When changing the SubMode set the LSN to zero and set the next LSN to the SubMode value. Note that a SubMode is set for the current selected DisplayMode, therefore it is necessary to set the DisplayMode prior to setting the SubMode. Also, not all DisplayModes have SubModes. If the DISPLAYMODE execute command has an invalid parameter, for any reason, the DISPLAYMODE bit will be set within the APFRA / STATUS / EXECERROR link.
2. The Complex Impedance dialog box must be active when issuing CmplxImped SubMode execute commands. This dialog box is activated automatically when the CmplxImped DisplayMode is selected and therefore is usually not an issue. Do not manually close this dialog box while controlling APfra via DDE.
3. The value returned by the APFRA / SYSTEM / DISPLAYMODE link will contain the DisplayMode in the LSN and the SubMode (if exists) in the 2nd LSN. This is the same format as the execute link with the exception that all information is present, whereas the execute link requires the DisplayMode and SubMode to be sent separately.

Using DDE in Microsoft Excel

Note : DDE links may not work while the Excel Help Assistant is active (Office97 and future versions) unless APfra is the active application. It is recommended that the Help Assistant be closed during DDE sessions to avoid potential problems.

It is recommended the user be familiar with Excel and Excel Visual Basic programming. Also knowledge of APfra's Services, Topics & Items is essential (detailed above). For use with APfra there are three types of DDE links which are useful. These are:

1. Hot data links for single values. Used to receive analyzer frequency points, source level, etc...
2. Hot data links for arrays of numbers. Used to receive the sweep arrays for Frequency and data.
3. Execute links to send commands to APfra (i.e. Start sweep, stop sweep, load default settings, etc...).

Hot links to data items of single values

Excel provides a simple method of establishing a data hot link. To start a hot link, enter into the cell:

`=Service|Topic!Item`

Select the cell to contain the data then enter an equal sign (=) followed by the name of the Service (the service is always APFRA), a vertical bar (may be found above the back slash), the Topic name (either DATA, SYSTEM, CONTROL, or STATUS), an exclamation point (!), then finally the Item name (i.e. POINTS, SWEEPSTATE, etc...). As an example, the following line when typed into a cell will display the number of sweep points in use, this cell will be updated automatically whenever the number of sweep points change:

`=APFRA|SYSTEM!POINTS`

Once the cell formula has been entered the DDE link is established and the 'conversation' will begin. Note: The DDE server (i.e. APfra) must be running or in the PATH to start the link.

Hot links to data items of arrays

This is similar to single value hot links but there are two important differences. First, multiple cells must be selected to hold the data (select as many cells as the number of sweep points). Multiple cells are selected by first selecting a single cell then dragging

the bottom-right corner of the cell down the spreadsheet. While the cells are selected type the DDE link string. The three data arrays available for hot link transfer are:

```
=APFRA|DATA!FREQ  
=APFRA|DATA!LDATA  
=APFRA|DATA!RDATA
```

Second, after typing in one of the above strings, enter the array formula by pressing CTRL+SHIFT+ENTER (hold the CTRL & SHIFT keys then press ENTER).

Execute links

Several APfra commands are available through DDE to help automate data collection and analysis. Execute commands are performed through cold link connections by opening a *DDE channel*. Commands are sent using this open channel and the channel is closed when no longer needed. The procedures to open, send commands through, and close channels are executed in Visual Basic routines. To open a DDE channel use the DDEInitiate command as follows:

```
ChannelID = DDEInitiate("Service", "Topic")
```

DDEInitiate returns a channel ID, this ID is used to execute commands for the Service and Topic used as arguments of the DDEInitiate. To send a command use the DDEExecute command:

```
DDEExecute ChannelID, "Item"
```

And when finished with the channel close it using the DDETerminate command:

```
DDETerminate(ChannelID)
```

There are various ways to manage ChannelID's. Here are two recommendations with examples.

First, If the channel is to be used infrequently (possibly only once) then place all DDE transactions in a single function. As an example, assume the configuration setup file BANDPASS.NAC is required whenever the spreadsheet is used. Also it is assumed that APfra has been installed using the default path location. The special function *Auto_Open()* is defined by Excel and automatically executes whenever the spreadsheet begins. The subroutine below uses this function to load the user defined example setup file 'bandpass.nac'.

```
Sub Auto_Open()  
    DDEChannel = DDEInitiate("APFRA", "SETUPLOAD")  
    DDEExecute DDEChannel,  
        "[C:\AP INSTRUMENTS\APFRA\SETUP\BANDPASS.NAC]"  
    DDETerminate(DDEChannel)  
End Sub
```

Next, If the channel is to be used frequently while the spreadsheet is active then it is easier to break up the DDE commands. In this case be sure to define the DDE Channel outside any function so it will have global variable scope. As an example, assume a macro is required that will start a sweep when called. This macro, ExecSweepStart(), may be called many times therefore the following programming methodology is used.

```
Dim DDEChannel
```

```
Sub Auto_Open()  
    :  
    : other initialization  
    :  
    DDEChannel = DDEInitiate("APFRA", "SWEEPSTATE")  
End Sub
```

```
Sub Auto_Close()  
    DDETerminate(DDEChannel)  
    :  
    : other exit procedures  
    :  
End Sub
```

```
Sub ExecSweepStart()  
    Rem ** Start sweep requires a SWEEPSTATE Item value of zero.  
    DDEExecute DDEChannel, "[0]"  
End Sub
```

As with `Auto_Open()`, `Auto_Close()` is defined in Excel to execute whenever the spreadsheet terminates.

Example Excel Spreadsheet

The spreadsheet provided with the analyzer software installation (APfra Dde Demo 300.xls) provides many examples of DDE communication and processing. This spreadsheet can be used as is or modified for custom use.

'APfra Dde Demo 300.xls' is a demonstration spreadsheet which uses every DDE link and execute command available. To use this spreadsheet first run APfra and then start Excel (if not already running), close the Excel Help Assistant if it is running, then open 'APfra Dde Demo 300.xls'. It is important to have APfra running prior to opening the spreadsheet. If any dialogs pop up asking if you would like to establish macros and/or connections answer 'Yes'. After a few seconds of initialization the spreadsheet should display the first tab (Control) with the current APfra parameters displayed in the column labeled 'Current Value'. The second tab (Data) displays the data in both tabular format and graphically, if sweep data is available in APfra (that is, if data traces are displayed) then this data will be present in the spreadsheet as well.

To change a parameter select (in the case of a combo box) or type (for edit boxes) the new parameter value in the 'Select' column of the Control panel, and then press the 'Send' button to the right of the combo/edit box. APfra will update as if the selection was made directly, then APfra will update the hot link parameter value (Current Value). If a problem with the parameter value is encountered (i.e. start frequency > 30MHz, etc...) then the change will not be made and an 'X' will appear in the 'Error' column. In this case the Current Value will not change.

Upon closing the spreadsheet it is best to respond with 'No' when asked if you would like to save changes, this ensures that the spreadsheet will not be altered. If you would like to make changes or extend the spreadsheet it is recommended that you

make a copy with a new name for your own use, keeping ‘APfra Dde Demo 300.xls’ intact for future reference.

All functions and macros (subroutines) are defined in a single module (Module1). The Excel menu item *Tools>Macro>Visual Basic Editor* will bring up the module for viewing/editing.

4

Application Notes

Introduction to Analog Network Measurements

Network analysis and frequency response measurements determine the most fundamental properties of a given network. These properties include the frequency response transfer function, input/output impedance and group delay all over a given frequency range. In many electronic applications, including filters, amplifiers and systems with feedback the most important characteristic is the frequency response of that network, circuit or system. The frequency response gives the magnitude (gain or attenuation) and phase, as a function of frequency, between two desired points in the system under test. The frequency response is measured directly by a frequency response analyzer for voltage-voltage transfer functions. High frequency power transfer functions are measured by the addition of a power splitter and through-line terminations. Impedance can be calculated using a known reference resistor in series with the unknown network. Group delay can be derived from the phase data since it is the negative derivative of phase with respect to frequency.

In the case of filters the two quantities of interest are typically the stopband attenuation and the passband insertion loss along with possibly the group delay characteristic in the passband. With amplifiers the main quantity of interest is gain “flatness” over frequency in which case the 3 dB gain rolloff point defines the amplifiers bandwidth. With feedback systems, either electrical or electromechanical, the open and closed loop frequency response characterize the system. Feedback systems can exhibit unwanted oscillations, i.e. instabilities, unless the open loop response is evaluated, and appropriately compensated for, to ensure stability.

The frequency response function of an electrical network is defined as the sinusoidal output response divided by the sinusoidal input stimulus. The input and output can be voltage or current depending of the desired transfer function. Note that the frequency response is a *ratioed* quantity of output to input, and that the input and output are described by complex numbers or phasors. The frequency response, at each frequency point of interest, is then given by a complex number, or phasor. The phasor can be fully described by its magnitude and phase components. It is these quantities, the magnitude and phase of the input and output that are measured and ratioed by the frequency response analyzer to obtain the frequency response.

The B/A ratioed measurement described above is equivalent to subtracting the input signal from the output signal when each quantity is in logarithmic form. In the model 300 frequency response analyzer the network's input signal is, by convention, measured by

channel A and the output signal is measured by channel B. The expression B/A then describes the resulting frequency response transfer function.

Basic Measurement Procedures

The optimum frequency response analyzer measurement setup is, as expected, highly dependent on the circuit under test. The frequency range of interest, circuit gain, circuit impedance at the probe points and DC voltage levels are among the factors affecting the measurement setup. Passive circuits are generally easier to measure than active circuits because they have low noise levels, don't usually have special bias voltage requirements and are typically insensitive to source drive levels. Active circuits, on the other hand, may have the properties mentioned above that make measuring them in a linear mode of operation more challenging. It is important to have a good idea of what the measurement results should be before they are taken. The real value of network measurements is in finding the incalculable and the miscalculated frequency response.

Users that are new to network measurements should become familiar with the analyzer's operation by first measuring a simple passive network before advancing to measuring, for example, the loop gain of a high gain feedback circuit.

General Measurement Procedure

Using the virtual front panel set the frequency response analyzer parameters to the following:

1. In the FILE menu load a specific configuration previously defined and saved using the Open Setup menu selection. This will establish a set of system parameters for general use. Specific requirements are met by using the appropriate toolbar button or menu selection.
2. Set the desired frequency coverage by using the START and STOP or CENTER and SPAN toolbar buttons located in the sweep frequency toolbar. If the start frequency is less than 10 Hz then DC coupling will have to be selected in the receiver parameters toolbar.
3. If desired set the graph title by typing text in the title bar.
4. Decide on what stage(s) in the circuit the transfer function is to be measured. Locate the input node and output node of this network.

5. As depicted below, connect up the source probe and the channel A probe to the network's input node. Connect up the channel B probe to the network's output node. If the output impedance of the stage preceding the network under test is less than approximately 50 ohms then an isolation resistor may be needed to provide a high enough source drive level. Make sure that the x1, x10 switch on both channel A and B probes are in the same position.
6. If not in a continuous sweep mode then select this mode in the sweep control toolbar. Increase the source drive level, using the source parameters toolbar, from its minimum level until the graphics display shows a noise free plot. If the plot is not visible or only partly visible actuate the Autoscale function from the graph tools toolbar. Bandwidth can also be adjusted, using the receiver parameters toolbar, so as to optimize trace noise or sweep time. Take care not to increase the source drive level to a point such that the network under test is no longer operating in a linear mode of operation as this can give erroneous results.

Basic Measurement Setup:

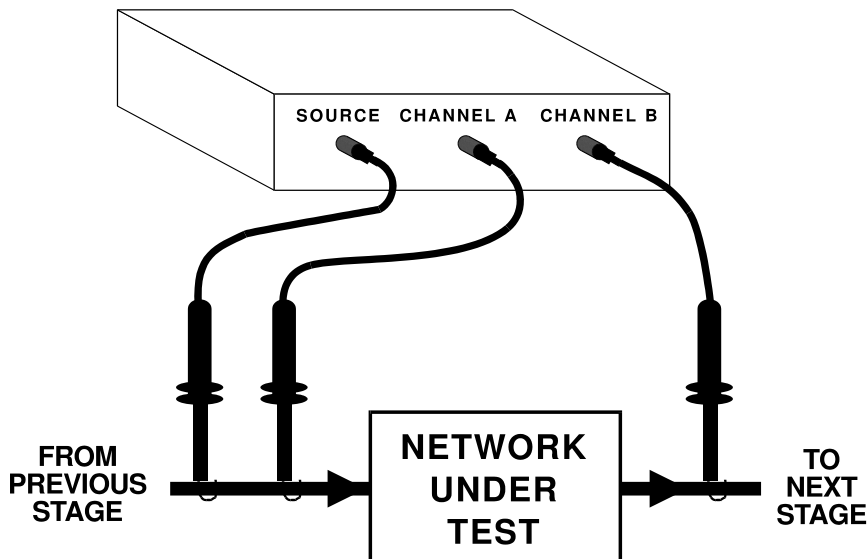

High Frequency Measurements

At frequencies higher than a few hundred kilohertz two important issues arise in network measurements. The first is that of isolation between a network's input and output nodes. The analyzer has a minimum dynamic range of 100 dB which can be compromised by coupling paths within the network under test or in the probe connections themselves. The source of this isolation problem can be either 1) conducted through "common mode impedances" and/or 2) radiated, with radiated coupling typically increasing with frequency. Basic RF layout and design practices reduce or eliminate this problem. It is recommended that coaxial cables with BNC interconnects be used above one megahertz.

The second issue is that of probe loading effects. For higher frequency measurements on high impedance circuits determine (very approximately) if the 80 pf capacitance of the probe tip in the x1 position on the output node will influence the measurement. The output node should have an impedance commensurate with the desired measurement accuracy. For example at 1MHz a capacitance of 80 pf has an impedance of 2K ohms and the node under test should then have an impedance of 200 ohms or less, at 1 MHz. This will give errors of less than 0.05 dB magnitude and 6 degrees phase. Although inconvenient, the effect of the probe shunt capacitance can be factored out knowing the actual output impedance of the circuit. The x10 position will reduce the probe capacitance to under 15 pf although the dynamic range of the instrument will typically be lowered by 20 dB in this setting. Note that BOTH channel A AND channel B probes must have the SAME setting or else the measurement will have an erroneous result of 20 dB.

Circuits with Nonzero DC Voltage Levels at the Input / Output Node

If the circuit's selected input node, also the frequency response analyzer's source connection and channel A connection, has a nonzero DC voltage it will be necessary use one of the following techniques: 1) DC offset the source (± 10 VDC max) to match the circuit's offset using the DC OFFSET entry in the source parameters toolbar or 2) AC couple the source to the circuit using a capacitor or transformer. If method 2 is used consideration will have to be given to the difficulty in obtaining a sufficiently low driving impedance at low frequencies with a reasonably sized coupling capacitor. In the case of a transformer low and high frequency response needs to be considered. The coupling method does not need to have a flat response since ratioed measurements cancel source flatness deviations. In both techniques the input channels must also be either: 1) AC coupled using the frequency response analyzer's internal coupling capacitor (≥ 10 Hz only), or 2) DC coupled which will enable the automatic DC offset tracking up to a maximum of ± 8 VDC. To allow sufficient voltage "headroom" for large amplitude signals the maximum DC offset should be ± 5 VDC.

Measuring Circuits with High Common Mode Voltages

For frequency response measurements on circuits that have large voltage offsets (>10 VDC) from ground it is necessary to couple the source to the circuit under test using a signal injection transformer covering the frequency range of interest. Using 10-to-1 probes for the receiver's input channels will increase the maximum input voltage to 200 Volts. For high voltages the receiver channels can also be either transformer coupled, connected using active differential probes, or connected using an isolation amplifier. Running a probe frequency calibration with any of the aforementioned connection schemes, with the probes in place, will remove (i.e. normalize) the frequency response of the probes.

Measuring Feedback Loop Frequency Response

In feedback circuits it is necessary to measure the gain and phase for the complete path around some chosen loop, i.e. the loop gain and phase. If the frequency response analyzer is connected such that the source and channel A are connected to the desired “beginning” point in the loop and channel B is connected to the desired “end” point in the loop the gain measured is the desired loop gain and the phase measured is the phase change around the loop. In the case of negative feedback, the phase change includes a 180 degree phase shift when the feedback signal is inverted in the loop.

The frequency response analyzer display shows a ± 180 degree phase range so the inversion in the feedback loop will cause any additional phase shifts beyond -180 degrees to “wrap around” and appear as a phase of $+180$ - (additional phase shifts). In a typical negative feedback circuit with one pole (i.e. 20 dB/decade rolloff) the phase would start off at $+180$ degrees and, at the pole frequency, show $+135$ degrees. The phase reading can then be directly interpreted as “phase margin” at the frequency where the loop gain magnitude is equal to one (0 dB).

Basic Setup For Feedback Loop Measurements:

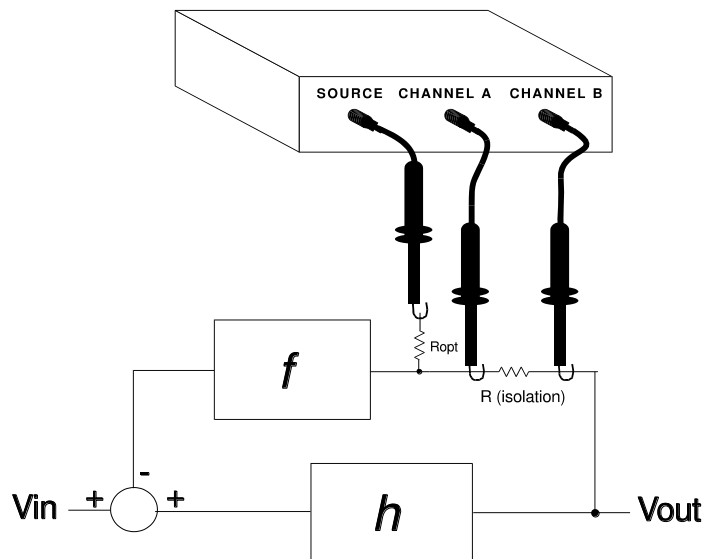

In most cases to make a loop gain measurement the feedback loop must be left closed due to high DC gain or bias conditions. These conditions would force the circuit into a nonlinear area of operation if the loop was opened making a valid measurement impossible. If the node at the source connection has a nonzero voltage then the source will have to be DC offset to match the node voltage or AC coupled using a capacitor or transformer. The resistor R_{opt} can be used to prevent circuit loading due to small differences in source and circuit voltages. For high frequency loop gain measurements the source probe capacitance as well as the input channel probe capacitance can have a destabilizing effect on the circuit - see the high frequency measurement note above. The source probe capacitance effect can be reduced by using a series resistor between the source and the circuit's selected node. Use a resistor as large as needed to maintain stability. The source drive level can be increased to the level required to obtain a noise free trace.

Two measurement methods are detailed below. The first is a DC coupled technique which has the advantages of a DC to 30 MHz frequency coverage. The disadvantage of this technique is that its implementation may require the use of a buffer amplifier. The second, AC coupled, technique is simpler in that it only requires a resistor and a transformer to implement. The disadvantage of this technique is that it is frequency limited by the bandwidth of the transformer used.

DC Coupled, Buffer Amplifier Method

Unless the feedback loop under test has a buffer stage with high input impedance and low output impedance it may be necessary to temporarily add such a stage to maintain the existing feedback loop characteristics and make a valid measurement. The diagram below shows the placement of such a temporary buffer and the frequency response analyzer connections for a feedback loop frequency response measurement. The buffer circuit below, with the 35 MHz bandwidth op-amps, adds approximately 3 degrees of phase shift at 1 MHz to the measurement. Lower speed op-amps can be used for lower frequencies, if desired. The circuit shown assumes $Z_{out} @ V_{out}$ is much lower than $R_{FEEDBACK}$ over the frequencies of interest. If this is not the case then to obtain the actual loop gain response it may be necessary to terminate the V_{out} node with an impedance equivalent to $R_{FEEDBACK}$ and to add a series impedance to $R_{FEEDBACK}$ equal to Z_{out} .

Buffer Circuit For DC Coupled Feedback Loop Measurements:

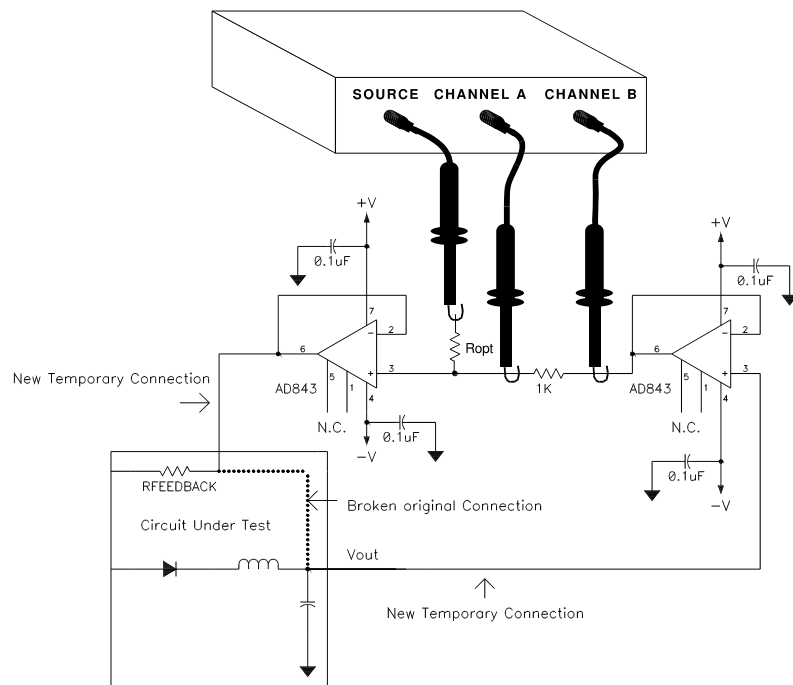

AC Coupled, Transformer Method

The secondary of a transformer is used in this technique to develop a drive voltage across a small resistor, typically 10 to 50 Ohms. This resistor is typically placed in series with the loop's feedback resistor as shown in the diagram below. The transformer's frequency response does not have to be flat over the measurement range but does need to provide an adequate drive level over the measurement range to ensure a good signal to noise ratio.

Configuration For Transformer Coupled Feedback Loop Measurements:

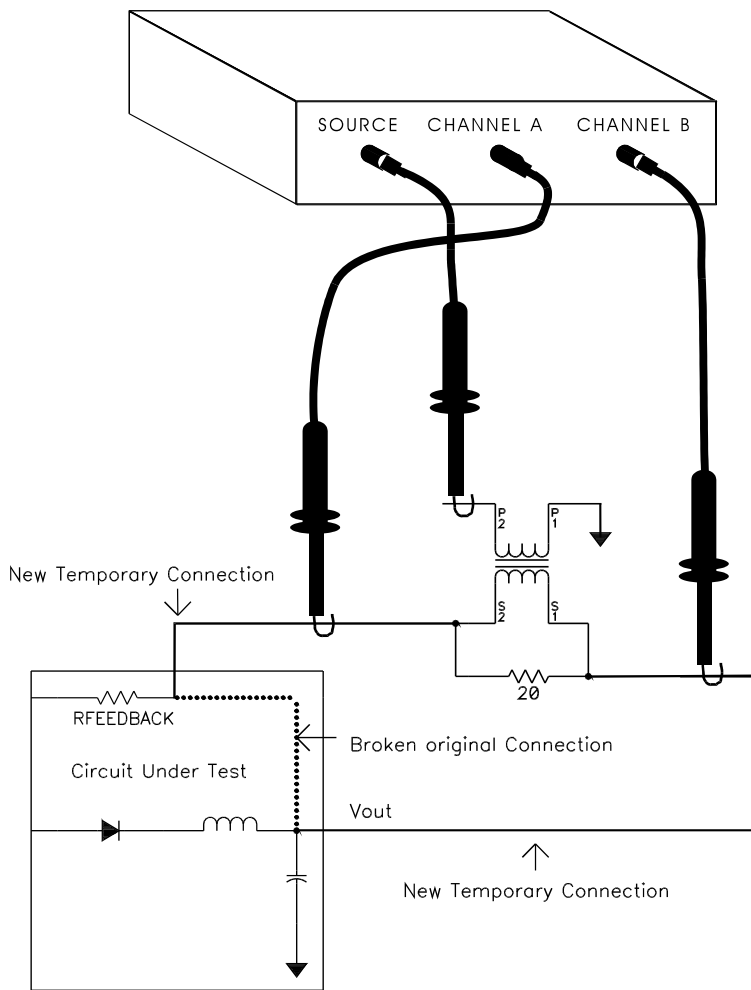

Measuring Complex Impedance

To measure the input or output impedance of a network the analyzer is connected to a known reference resistor, \mathbf{R} , that is in series with the network. As shown in the example topology below the source output and channel A are connected to one side of \mathbf{R} and the other side of \mathbf{R} is connected to channel B and the network under test. For best accuracy the resistor \mathbf{R} is chosen such that its impedance is within a factor of 5 or so of the expected impedance of the network under test, at the frequency of interest. The impedance calculations derived below are done automatically by the software when the Complex Impedance option is chosen within the Graph menu.

A choice of topologies allows the user to select a topology that best fits the measurement to be made. A choice of connection topologies are available for both high impedance networks, topologies 1&2 labeled HI-Z, and low impedance networks, topologies 3&4 labeled LO-Z. It is required to isolate the source using an isolation transformer when using the LO-Z topologies 3&4 due to the sense requirements of the input channel being on the low side of the source.

Impedance Measuring Setup:

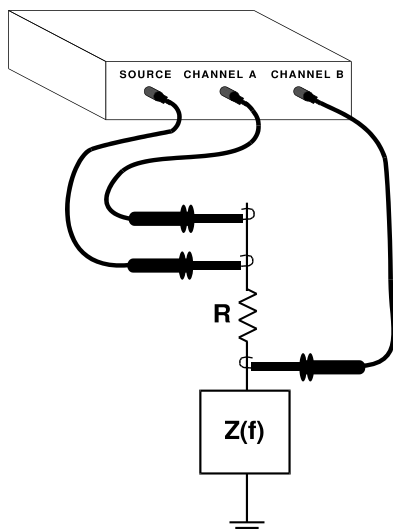

DUT Impedance Model shown with Parasitic Shunt and Series Elements:

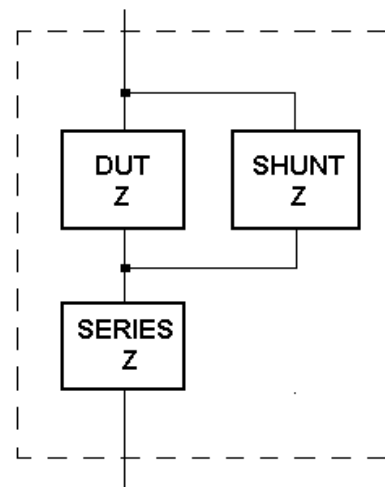

A choice of display modes are available which give options on how the complex impedance data is formatted and displayed. The display modes include polar, rectangular and equivalent circuit with a parallel or serial topology being options.

First order parasitic series and shunt elements, as introduced by the probes or other fixtures, can be optionally mathematically subtracted out. To mathematically eliminate the probe shunt capacitance, for example, choose the desired topology and connect the probes and network under test. Display the impedance as Equiv C & R with a series equivalent circuit. Temporarily remove the network under test (i.e. an open circuit) while keeping the probes connected, then using the shunt element parasitic compensation capacitance entry, adjust this capacitance value while reading the display to achieve the best approximation to an open circuit. To mathematically eliminate the probe series resistance temporarily remove the network under test and replace with a small resistance of known value (i.e. 1 Ohm) while keeping the probes connected. Display the impedance as Equiv L & R with a series equivalent circuit. Using the series element parasitic compensation resistance entry, adjust this resistance value while reading the display to achieve the best approximation to this known value. Reinsert the network under test to make the final measurement.

Complex Impedance Measurement Calculations

Let the transfer function measured by the analyzer be $\mathbf{H}(f)$, the unknown complex impedance, $\mathbf{Z}(f) = x + j \cdot y$, is then given by: $\mathbf{Z}(f) = \mathbf{R} \cdot \mathbf{H}(f) / (1 - \mathbf{H}(f))$. This result is derived using the generalized voltage divider formula with the substitution of $\mathbf{V}_B = \mathbf{H} \cdot \mathbf{V}_A$. First the magnitude of $\mathbf{H}(f)$ is converted from dB's to linear form by dividing by 20 and taking the antilog (base 10). The phase is used directly as read from the analyzer taking care to include the sign. The converted magnitude along with the phase now represents $\mathbf{H}(f)$ in polar form, and is then converted to rectangular form and substituted into the formula above. The resulting complex number is the impedance in ohms and will typically have a real part, x , representing the equivalent series resistance, and a imaginary part, y , representing the equivalent reactance of the network under test. A capacitive reactance will have a negative imaginary part, while an inductive reactance will have a positive imaginary part. The equivalent capacitance is given by $\mathbf{C} = -1 / (2 \cdot \pi \cdot f \cdot y)$ and the equivalent inductance given by $\mathbf{L} = y / (2 \cdot \pi \cdot f)$ where f is the measurement frequency in Hz.

Line Current Harmonic Measurements

A measurement mode for line current harmonic precompliance testing can be accomplished by using the Absolute Magnitude Display as chosen within the Graph menu. By setting up an fpl file list of the first forty line harmonic frequencies this mode can graph a plot of the harmonics of the power line current. Choose a receiver bandwidth of 10 Hz. It is highly recommended that the IEC standard be obtained and understood by the user before this test is undertaken. A copy of this standard is available through ANSI. The current is measured using an external current transducer, connected to channel A or B. The current transducer frequency response bandwidth is required to be flat from 50 Hz to 2.5 KHz. Note that the current transducer must have an output that is safety isolated and meets the SELV (Safety Exposed Low Voltage) requirements when connected to measure line current.

Line Current Harmonic Measurement Setup:

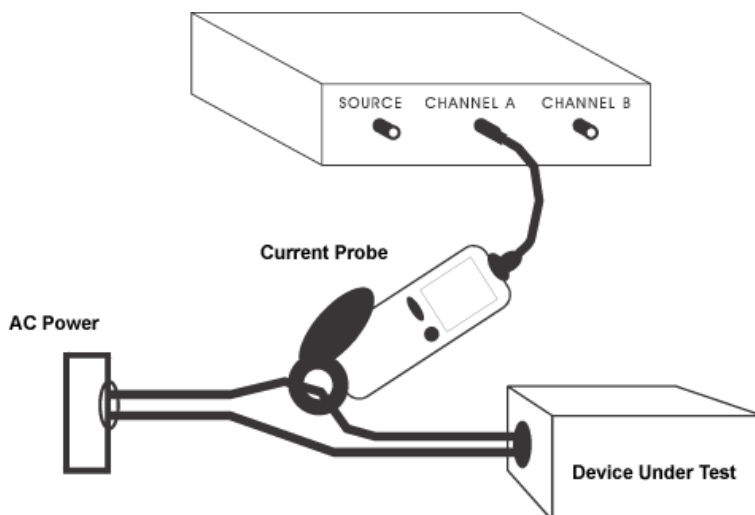

Power Transmission/Reflection Measurements

In applications such as passive filters and circuits for communications the parameters of interest involve not voltage transfer functions but rather power transfer functions. Because power can be reflected as well as transmitted through a network due to impedance mismatches the voltage and power transfer functions are not necessarily the same. The model 300 frequency response analyzer, in its most basic configuration, measures voltage/voltage transfer functions since it has high impedance inputs. To measure power transfer functions the frequency response analyzer inputs need to be terminated, using feedthrough terminations, to the desired impedance (typically 50 or 75 ohms). This will convert the power into a voltage which is measured by the analyzer. Also the measurement configuration must be able to determine the actual power transmitted through or reflected from the network under test. This is accomplished by using a power splitter and, in the case of reflection measurements, a directional coupler. The model 300 frequency response analyzer has the capability to measure transmission (S21 or S12) as well as the return loss of a reflection measurement directly. The derived quantities including the reflection coefficient, VSWR and impedance can be calculated from the return loss measurement's magnitude and phase information using the relationships given below.

Reflection coefficient magnitude = $10^{(-\text{return loss}/20)}$ where the return loss is expressed as a positive quantity in dB. The reflection coefficient magnitude is between 0 and 1.

Reflection coefficient phase = the phase measured at the return loss measurement.

VSWR = $(1 + \text{reflection coefficient magnitude}) / (1 - \text{reflection coefficient magnitude})$.

Impedance = $\text{Characteristic impedance (i.e. 50 Ohms)} * (1 + \text{reflection coefficient}) / (1 - \text{reflection coefficient})$

Transmission Measurements

In the case of transmission measurements the power incident to the network under test can be determined by sampling the incident source power using a power splitter and making a ratioed measurement of the output power to input power. As shown in the drawing (below) the sampled incident power is measured by channel A while the transmitted power is measured by channel B. Note that the input channels A and B must be terminated to the

characteristic impedance of the network under test using feedthrough terminations. A probe frequency calibration can be performed with the power splitter in place and a through line substituted for the network under test for enhanced accuracy. The power splitter can be a simple resistive splitter shown below which will result in a 6 dB power loss from the source to the network under test. A low loss transformer coupled splitter such as a Mini-Circuits model ZSC-2-2 can also be used.

Transmission Measuring Setup:

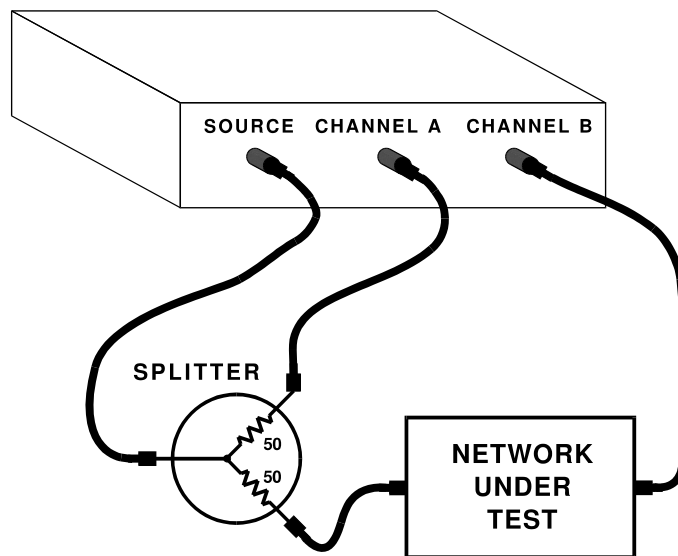

Reflection or Return Loss Measurements

With reflection measurements the power reflected from the network under test back toward the source is the quantity of interest. The reflected power is measured by a directional coupler such as a Mini-Circuits model ZDC-15-6. The directional coupler has a tap which represents a portion (i.e. -15 dB) of the reflected power. A return loss measurement can be made by taking a ratioed measurement of the incident power to the reflected power. The incident source power is sampled using a power splitter. As shown in the drawing (below) the sampled incident power is measured by channel B while the reflected power, as sampled

from the coupler tap, is measured by channel A. This ratio is taken to keep return loss a positive quantity. Note that the directional coupler's output port is connected to the power splitter while the coupler's input port is connected to the network under test. This is because it is the reflected power from the test network that enters the coupler's input port. Note that the input channels A and B must be terminated to the characteristic impedance of the network under test using feedthrough terminations. A probe frequency response calibration **must** be performed with the power splitter and directional coupler in place using a short substituted for the network under test. The short will give a theoretical return loss of 0 dB with a phase shift of 180 degrees and gives the reference point by which the return loss is measured. The -15 dB reflected power coupling tap of the directional coupler is calibrated out by the probe frequency response calibration procedure.

Reflection Measuring Setup:

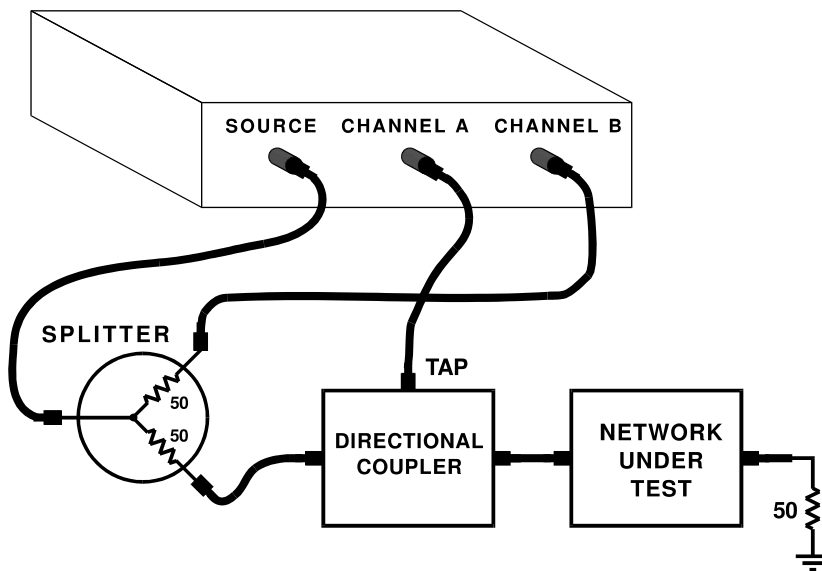

Appendix A: Theory of Operation

The model 300's frequency response analyzer system is comprised of a host PC and analyzer unit. The host PC provides the operator I/O, file storage and data post-processing. The Analyzer unit contains the frequency source output and the two input, or receiver channels, as well as the power supply and USB I/O circuitry.

The frequency response analyzer uses a "swept sine" approach to measure the transfer function of the network under test. This approach requires a sinusoidal, variable frequency, source output and two input channels capable of sampling the sinusoidal input over a broad frequency range. The source is of the DDS or direct digital synthesis type which meets the requirements of fast frequency changes, logarithmic or linear sweeps, wide frequency range and low parts count. The receiver is of the heterodyning type which enables a broad frequency range with a fixed low frequency I.F. for high accuracy and low noise analog to digital conversion.

Both the source and L.O. use a DDS source which functions by accumulating a selectable phase increment at the system clock rate. This accumulated phase value is then directly mapped to the sine value using a ROM lookup table. The sine value is then converted to a voltage using a high speed DAC, the output of which is low pass filtered to remove aliases. The L.O. output is used directly to drive the L.O. side of the receiver mixers. The source output, however, is passed through a stepped attenuator giving 0 to 63 dB's of attenuation. The attenuator's output is then DC offset by a user selected amount and buffered enabling the source output to drive 50 ohm loads.

The receiver channels A and B are identical thus the following description applies to both. The input signal drives a high impedance input buffer which in turn drives a stage capable of being DC offset for automatic DC offset tracking. The offset stage then drives an amplifier stage switched by the DSP uP for maximum signal to noise ratio. The amplifiers output drives the signal side of the mixer resulting in a mixer output that is a fixed I.F.. The I.F. signal is then low pass filtered to remove aliases and sampled by the analog to digital converter.

The receiver's analog to digital converter output is sent to the DSP uP over the serial interface. The DSP uP converts the data from both input channels, in real time, to complex numbers representing the phase and magnitude of the sinusoids at the channel A and B inputs. The DSP uP then passes these complex numbers to the PC for error correction and scaling for presentation on the PC's graphics display.

Appendix B: Measurement Accuracy

The basic accuracy of the analyzer is specified to be 0.025 dB magnitude and 0.2 degrees phase. These specifications assume that a system calibration has been performed after a 30 minute warm-up period at the operating ambient temperature. The analyzer's accuracy can be undermined by changing or swapping the input probes after calibration has been performed.

There are a number of factors that determine the accuracy, or lack thereof (uncertainty or error) of a given frequency response measurement made by the frequency response analyzer. They are listed below in an order which does not necessarily reflect their significance.

Possible error contributing factors **external** to the analyzer include:

Probe Loading

Probe Compensation

Transmission Line Effects

Possible error contributing factors **internal** to the analyzer include:

Signal to Noise Ratio

Source Frequency Accuracy

Temperature Drift

Receiver Linearity

To obtain the worst case measurement error the errors from all of these factors need to be summed together as they relate to a given measurement situation. The term 'res', as used in the charts below, indicates the values are below 0.01 dB magnitude or 0.1 degrees phase.

Probe Loading Error

Probe impedance, chiefly capacitance, can cause loading of the circuit under test and can be a significant error source as described in the discussion on high frequency measurements.

Probe Compensation Error

Ten-to-one (x10) probes, needed for reducing the probe loading effect introduce a frequency response error. The frequency response error can be canceled by performing a frequency

response calibration. The adjustment procedure is performed once at the factory on the included probes and should be performed periodically as follows: Set the analyzer for a 0.994 V rms signal level output and sweep from 100 Hz to 100 kHz (log sweep). Connect the source and input channels together. Place one probe in the x1 position, if available, or use a 1:1 cable. Place the other probe in the x10 position. Using a small screwdriver or adjustment tool set the x10 probe compensation adjustment for maximum flatness. Likewise, adjust the second x10 probe in a similar manner keeping the probe on its assigned channel (do not swap probes back and forth between channels).

Transmission Line Effects

When using coaxial cables at higher frequencies and long cable lengths the transmission line effects give rise to "standing wave patterns" on cables unless the cables are properly terminated at their endpoints with the cable's characteristic impedance. The analyzer's inputs have a one megohm impedance which may need to be terminated to the cables impedance. To avoid this type of error use through-line terminators at the analyzer's input channel BNC's.

Signal to Noise Ratio Error

This error term is labeled "signal to noise ratio" or SNR and is the difference, in dB's, between the analyzer's receiver noise floor and the smallest of the two input channel's signal magnitude. The analyzer's noise floor is specified to be at least 100 dB's below the largest allowable signal which is 1.7 volts rms. An input signal at the worst case noise floor level would then have a magnitude of approximately 18 microvolts rms and the SNR would be 0 dB. The analyzer's typical noise floor is approximately 5uV rms using a IF bandwidth of 10 Hz. This type of error is a random quantity that manifests itself as trace noise. The chart below lists the measurement error as a function of SNR.

Signal to Noise Ratio Error Chart

Signal Strength	SNR in dB's	Mag. Error (dB)	Phase Error (deg.)
18 uV	0	3	45
56 uV	10	0.414	13.6
180 uV	20	0.043	5.7
560 uV	30	0.0043 (< res)	1.81
1.8 mV	40	< res	0.573
5.6 mV	50	< res	0.181
18 mV	60	< res	0.0573 (< res)
56 mV or more	70 or more	< res	< res

Source Frequency Error

The source frequency is accurate to 100 ppm (0.01%) which makes its consideration important only on circuits with extremely high Q such as crystal filters.

Temperature Drift Error

The temperature drift error is due to magnitude and phase changes with the analyzer's internal temperature changing. This results from the operating temperature being different from the temperature at the time the frequency calibration was performed. This error source can be minimized by performing a frequency calibration at the ambient operating temperature after a 30 minute warm-up period. The expected worst case temperature coefficients are 0.005 dB magnitude and 0.02 degree phase, per degree Celsius.

Receiver Linearity Error

Since the frequency calibration is performed at a single, high, input level any variations in the analyzer's linearity will cause a magnitude error at other, significantly different, input levels. The chart below gives this error as a function of input level.

Receiver Linearity Error Chart

Input Signal Level	Magnitude Error in dB's
0.1 mV	0.30
1 mV	0.15
10 mV	0.01
>10 mV	< res

Appendix C: Specifications

SYSTEM

PARAMETER	TYPICAL SPEC.	MIN. / MAX. SPEC.
Sweep Speed, Per Point ¹	6 msec. (2 GHz PC)	PC Dependent
Source / Receiver Isolation	120 dB	100 dB min.
Temperature, Operating		5 °C / 35 °C
Temperature, Storage		-40 °C / 70 °C
Source / Receiver :		
Weight	10 lbs.	
Dimensions	4.5"H x 10"W x 12.5"L	
Analyzer (BNC) ground to PC ground common mode voltage		42V Peak
Input AC Voltage Range	115VAC, 230VAC	+/- 10%
Input AC Frequency	50-60Hz	
Input AC Power	80 Watts	

SOURCE

PARAMETER	TYPICAL SPEC.	MIN. / MAX. SPEC.
Frequency Accuracy		100 ppm +/- 0.01 Hz
Frequency Resolution	0.01 Hz	
Frequency Range		0.01 Hz – 30 MHz
Flatness, DC to 1 MHz ²	+/- 0.2 dB	
1 to 30 MHz	+/- 1 dB	
Harmonics	- 40 dBc	
Spurious, Exc. Harmonics	- 55 dBc	
AC Output Level Range		1.25 mV / 1.77V rms (into 1M Ohm), 5mV / 7.08V rms in high level mode
AC Output Level Error ²		+/- 15 %
DC Offset Range		-10 / +10 V Peak
DC Offset Error		+/- 2 %
Residual DC Offset		+/- 30 mV
Maximum Peak Current Output	500 mA	
Output Impedance	50 Ohms (2 Ohms in high level mode)	
Absolute Maximum Safe Voltage at Source Output		+/- 15 Volts Peak

RECEIVER

PARAMETER	TYPICAL SPEC.	MIN. / MAX. SPEC.
Dynamic Range ^{3,4} < 5 MHz	115 dB	100 dB min.
>= 5 MHz	95 dB	90 dB min.
B/A Mag Accuracy ³ < 1 MHz	+/- 0.025 dB	See appendix B
>= 1 MHz	+/- 0.05 dB	
Abs. Magnitude Accuracy < 1MHz	+/- 2 %	
>= 1MHz, < 5MHz	+/- 5 %	
>= 5MHz	+/- 10 %	
Phase Accuracy ³ < 1 MHz	+/- 0.2 degree	See appendix B
>= 1 MHz	+/- 0.8 degree	
Resolution (IF) Bandwidth	Depends on frequency and Bandwidth selection	0.01 Hz / 1 KHz
Input Signal Range(AC) ³	5 uV to 1.77 V rms	17.7 uV / 1.77 V rms
Input Signal Range(AC+DC)	-5 / + 5 V Peak	-8 / + 8 V Peak
A to B Isolation < 5 MHz	115 dB	100 dB min.
>= 5 MHz	95 dB	90 dB min.
Input Imped., x1 probe	1 Megohm	
Input Imped., x10 probe	10 Megohm	
Input Cap., at BNC conn.	25 pF	
Absolute Maximum Safe Voltage at Receiver Input		+/- 15 V Peak

¹ For measurement frequencies > 11KHz. A minimum of 1.2 cycles at the source frequency are used giving a minimum time per point of (1.2/frequency) + 2 ms.

² Ratioed measurements cancel source flatness deviations and absolute source level errors.

³ Using (IF) bandwidth of 10 Hz or less and 50 sweep Averages.

⁴ Spurious free dynamic range is 90dB minimum at the following frequencies: N*100KHz and N*100KHz-20KHz for N=1 to 6.

Specifications subject to change without notice

Appendix D: File Types; Use and Format

Below is a description of the various files which are used by the frequency response analyzer windows software.

Filename.nac

Files of extension .nac are user defined setup files. These files are created using the menu command [File|Save Setup As...].

Filename.dat

Data files created with the [File|Save Data] commands are text files of sweep data. Both realtime and Master data are saved in exactly the same format and are indistinguishable. When copying, saving, or backing up data files be sure to include the raw files as well (see .raw files below). The data is written in the following format:

A one line header describing the three columns of data followed by one line per data point, On each line are three (3) tab separated values ordered as Frequency, Left Graph data, and Right Graph data. The header text is unique and specific for each graph display mode and sub-mode. The header text strings for each graph display mode is defined as follows:

Display Mode	Column 1 Header	Column 2 Header	Column 3 Header
Magnitude & Phase or	Frequency Frequency	Mag Mag [B/A]	Phase Phase [B-A]
Absolute Mag A & B	Frequency	ChA Abs	ChB Abs.
Complex Impedance			
Impedance (Rect)	Frequency	Imp. Real	Imp. Imag
Impedance (Polar)	Frequency	Imp. Mag	Imp. Angle
Equiv. C & R	Frequency	Equiv C	Equiv R
Equiv C & Dissipation	Frequency	Equiv C	Dissipation
Equiv L & R	Frequency	Equiv L	Equiv R
Equiv L & Quality	Frequency	Equiv L	Quality

Appendix D: File Types; Use and Format

The first few lines of a sample 'Mag & Phase' .dat file is shown below. Notice that the headers do not line up above each column because they must be separated by a single tab.

```
Frequency      Mag [B/A]      Phase [B-A]
+1.000000000000000E+005 +8.58853708270465E-005 +6.60194589390718E+001
+2.50505050505051E+005 +1.92421471682001E-004 +6.93981250534969E+001
+4.01010101010101E+005 +2.96826471082548E-004 +6.87845802300116E+001
+5.51515151515152E+005 +3.80347335893323E-004 +6.55793246075406E+001
+7.02020202020202E+005 +4.65889577918372E-004 +6.34051669771227E+001
+8.52525252525253E+005 +5.45084391624339E-004 +6.21402495420856E+001
+1.00303030303030E+006 +6.13806104602791E-004 +5.87649162977190E+001
+1.15353535353535E+006 +6.77996977924467E-004 +5.76638399853415E+001
:
:
```

Filename.raw

Raw files are binary files which contain the primitive data associated with a data file (above) of the same filename. When saving a data file a 'raw' file is automatically created and saved with the same filename, also, loading a data file will automatically load the raw file if it exists.

It is important to note that raw files cannot be processed by themselves and are always associated with a data (.dat) file. This association is through their filenames, both the .dat and .raw have the same filename. Therefore renaming a data file without renaming its associated raw file will disassociate the two. Also, renaming a raw file to another data filename (which it was not created with) is not supported and most likely will have unpredictable behavior.

Filename.fpl

A Frequency Points List (.fpl) file is used to define specific frequency values for a sweep. The format of this text file is described in detail below (*Frequency Point List (FPL) Files*).

Filename.cal

This file is generated by a probe calibration. They are binary files and should not be edited. Creating and loading probe calibration files is accomplished through the [Tools][Calibration...] dialog box.

Frequency Point List (FPL) Files

As an alternate method of frequency sweeping, the software allows a series of frequency values, stored in a file, to be used as the data collection points. These files have the extension .fpl (Frequency Points List) and the format is as follows :

An ASCII text file with one frequency value per line. The value may be either decimal or exponential format. It is important that there are no blank lines (even at the top of the file) or extra carriage returns, also, the frequencies must increase from the top of the file on down.

The following is a valid 5 point FPL file :

```
100.38
103.45
1E+4
5.23E+4
800000.9654
```

The [File | Save Data As...] menu option can be helpful in creating FPL files. Suppose a 400 point logarithmic sweep from 1K to 100K is desired, but the sweep must include the exact value of 10500.00. This can be accomplished by performing a standard log sweep with the limits specified, then save the data to a file (creating a .dat file). By deleting all but the first column in the .dat file and changing the extension to .fpl a 400 point FPL file of the frequency values used in the logarithmic sweep is created. Now find the frequency value closest to 10500.00, +1.05826072562617E+004, and change it to 10500.00. This file can now be used to perform the required sweep.

Appendix E: Default Setup Values

Sweep

Sweep Points	100
Sweep Frequency Input	Start / Stop
Sweep Start Frequency	10 Hz
Sweep Stop Frequency	30,000,000 Hz
Sweep Center Frequency	15,000,005 Hz
Sweep Span	29,999,990 Hz
Sweep Averaging	Off
Sweep Averaging Factor	20
Sweep Mode	Continuous
Sweep Type	Linear
Sweep Dwell	Auto
Sweep Dwell User Value	0 ms

Source

Source Output	On
Source DC Offset (Source)	0.0 V
Source Level	1.25 mV
Source Level Mode	Normal

Receiver

Receiver Coupling	AC
Receiver Preamp	Auto
Receiver BandWidth	1 Khz

Colors

Grid	Light Gray
------	------------

Markers	Magenta
Left Trace	Light Blue
Left Master Trace	Dark Blue
Right Trace	Light Red
Right Master Trace	Dark Red

Data Format

Mag & Phase	Frequency	Eng / 2
	Left Trace	Std / 2
	Right Trace	Std / 2
	Delta	Exp / 1
Abs Mag	Frequency	Eng / 2
	Left Trace	Std / 3
	Right Trace	Std / 3
	Delta	Exp / 1
Cmplx Imp	Frequency	Eng / 2
	Left Trace	Exp / 3
	Right Trace	Exp / 3
	Delta	Exp / 1
Trace Display		Left & Right Trace
Phase Format		+/- 180°
Title		Clear

Complex Impedance Setup

Reference Resistor	1000 ohms
Equivalent Circuit Mode	Series
Display Mode	Impedance (Rect)

Appendix F: Repair and Warranty Information

Repair

If after reviewing and implementing the performance test procedures in appendix H the unit is still non-operational then proceed as follows:

1. Contact AP Instruments for further assistance and, if needed, a return authorization.
2. Pack the instrument, including all accessories, in the original packing and shipping materials. If the original shipping materials are not available ensure that there is at least four inches of packing material surrounding the instrument and the individual components have been separately wrapped to prevent scratches during shipping.
3. Ship the package, insured for full value, to the address obtained in the factory return authorization contact above.

Warranty

The Model 300 comes with a one year limited warranty. During the warranty period, AP Instruments will, at its option, either repair or replace the products that prove to be defective. Should AP Instruments be unable to repair or replace the product within a reasonable amount of time, a refund of the purchase price may be given upon return of the product.

Warranty Exclusions

The warranty on your Model 300 shall not apply to defects resulting from:

- Customer supplied software or interfacing.
- Damage by accident or abuse.
- Unauthorized modifications or misuse.
- Operation outside the environmental specifications of the product.

SPECIFICALLY, AP INSTRUMENTS DOES NOT EXTEND TO YOU, THE END USER, ANY EXPRESS WARRANTY OR ANY IMPLIED WARRANTY OF MERCHANTABILITY, FITNESS FOR USE OR FITNESS FOR ANY PARTICULAR PURPOSE IN CONNECTION WITH THE HARDWARE, SOFTWARE, OR FIRMWARE EMBODIED IN OR USED IN CONJUNCTION WITH THIS PRODUCT EVEN IF AP INSTRUMENTS HAS BEEN ADVISED OF THAT PURPOSE.

AP INSTRUMENTS IS NOT RESPONSIBLE FOR ANY DAMAGES OR LOSS, WHETHER DIRECT INCIDENTAL OR CONSEQUENTIAL, WHICH YOU, THE END USER, MAY EXPERIENCE AS RESULT OF YOUR PURCHASE OR USE OF THE HARDWARE, SOFTWARE OR FIRMWARE EMBODIED IN OR USED IN CONJUNCTION WITH THIS PRODUCT.

Some states do not allow limitation of implied warranties, or exclusion or limitation of incidental or consequential damages, so the above limitations may not apply to you. This warranty gives you specific legal rights. You may have other rights which may vary from state to state.

Appendix G: AC Power Fuse Replacement

The AC power fuses located on the rear panel may need replacement if the analyzer fails to power up (no green power indicator) or if the line selector switch was initially in the incorrect position for the local AC mains voltage. The fuse specification for 115VAC mains is: 5x20mm 250V rated 1.25Amp time delay (T). The fuse specification for 230VAC mains is: 5x20mm 250V rated 0.63Amp time delay (T). Two identical fuses are required.

To replace the fuses first remove the AC line cord from the rear panel. The fuse tray is removed by prying the tray's tab away from the rear panel. With the tray removed the old fuses can then be replaced.

Verify that the local AC mains voltage level matches the setting of the line voltage selector switch on the rear panel. Set the switch as required for the AC mains supply, either 115VAC or 230VAC as appropriate.

Rear panel AC input section:

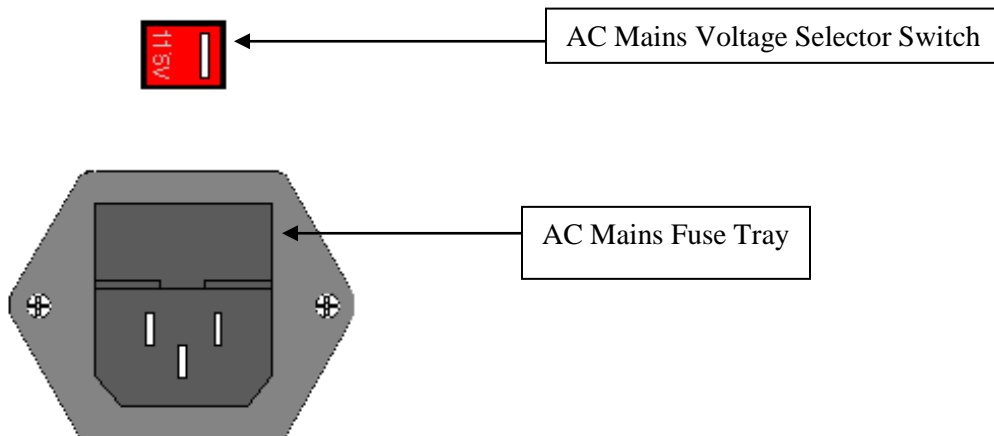

Appendix H: **System Calibration / Performance Verification**

System Calibration

Note that the probe calibration procedure, as performed by the user using the software's Tools menu, is not a system calibration and only compensates for the effects of the probes.

To obtain accurate measurements the system should be calibrated periodically. It is recommended that system calibration be performed annually. To obtain a NIST traceable calibration the analyzer must be sent to AP Instruments. AP Instruments uses custom hardware fixtures and data logging software to verify the results of the calibration with NIST traceable quantities.

Performance verification tests are outlined below. All tests are performed at room temperature, i.e. 23 +/- 5 deg. Celsius with relative humidity: 20-80%, with the analyzer and test equipment turned on at least 30 minutes prior to testing.

Quick Performance Test

This test gives a qualitative evaluation of the analyzer's condition allowing the user to determine if the analyzer is operating normally.

Hardware connections: Hardware connections: Analyzer receiver's input channels A and B connected to the source through a BNC Tee connector and two identical 12 inch BNC cables. Alternatively the connection can be made using the included probes set to the x1 position. The use of other than short BNC cables will limit the test frequency to 1MHz due to the effects of the probe's ground leads.

Initial analyzer settings:

View Menu: All toolbars except Marker Functions Toolbar selected. The Extended Functions Interface unchecked (disabled).

Graph Menu: Magnitude and Phase selected.

Sweep Control Toolbar: Sweep Mode in continuous mode, Sweep Type is Log x and Points equal to 100

Sweep Frequency Toolbar: Start/Stop mode selected, Start Frequency is 10 Hz, Stop Frequency is 30 MHz.

Source Parameters Toolbar: Source On and Source Level is 1 volt. High source level mode is disabled.

Receiver Parameters Toolbar: AC Coupling active and Bandwidth set to 100 Hz.

Graph Tools Toolbar: Markers enabled.

Using the Sweep Control Toolbar start the sweep. After a full sweep has been completed use the Graph Tools Toolbar to activate the autoscale button.

The observed Magnitude and Phase data should be within the following limits up to 1 MHz; Magnitude: 0 dB+/- 0.05 dB maximum deviation. Phase: 0 Degree+/- 0.5 Degree maximum deviation. From 1 MHz to 30 MHz, when using the 12 inch BNC cables, the observed Magnitude and Phase data should be within the following limits: Magnitude: 0 dB+/- 0.1 dB maximum deviation. Phase: 0 Degree +/- 1.5 Degrees maximum deviation.

Additionally, perform the next test by using the Graph Menu to select Absolute Magnitude Channels A&B. After a full sweep has been completed use the Graph Tools Toolbar to activate the autoscale button. The observed Absolute Magnitude for both channels A and B should be within the following limits up to 1 MHz: Voltage: 0.95 to 1.05 VRMS.

Full Performance Tests

The full performance tests include the following:

Source: Frequency, AC Level, DC Offset, DC Null

Receiver: Magnitude and Phase, Absolute Magnitude, Dynamic Range

Recommended performance verification test equipment:

Mfg.	Model	Description
Agilent	34410A/34401A	Multimeter (DVM)
Agilent	53131A	Universal Counter

Other supplies recommended:

One BNC Tee adapter, two identical 12 inch 50 Ohm male to male BNC cables, one BNC to banana jack adapter for the DVM, one 50 Ohm BNC terminator. One male to male 50 Ohm

BNC cable of approximately 24 -48 inches. One each of the 20, 40, 60, 80 dB attenuators (see below).

Since high value precision attenuators may be difficult to obtain the following attenuator circuit can be constructed. Keeping the leads short will allow use up to approximately 1 MHz. Wire a female BNC connector to the attenuator's input and a male BNC connector to the attenuator's output. These attenuators are adjusted for the correct attenuation value by applying a stable DC voltage (5-10v) at the input and using the DC ratio function of the Agilent 34410A DVM to measure the output/input ratio. Careful adjustment to within 0.06% of the target ratio is required to ensure the attenuator is accurate within +/-0.005 dB.

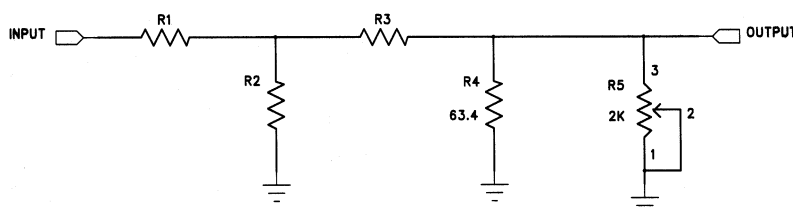

Attenuation Value		R1	R2	R3	R4	R5
dB	Linear ratio					
20	0.1	169	316	215	63.4	2K (Pot)
40	0.01	2.37K	1K	1K	63.4	2K (Pot)
60	0.001	4.87K	499	4.87K	63.4	2K (Pot)
80	0.0001	17.8K	316	10K	63.4	2K (Pot)

Source Frequency Test

This test measures the source frequency accuracy at 1MHz.

Hardware connections: Analyzer's source output to the frequency counter's input 1 using a BNC cable.

Initial frequency counter's settings: Default.

Initial analyzer settings:

View Menu: All toolbars except Marker Functions Toolbar selected. The Extended Functions Interface unchecked (disabled).

Sweep Control Toolbar: Sweep Mode in continuous mode, Sweep Type is Lin x and Points equal to 100

Sweep Frequency Toolbar: Center/Span mode selected, Center Frequency is 1.0 MHz, Span Frequency is 0 Hz.

Source Parameters Toolbar: Source On and Source Level is 1 volt. High source level mode is disabled.

Using the Sweep Control Toolbar start the sweep and record the counters frequency.
Minimum frequency: 999,900 Hz. Maximum frequency: 1,000,100 Hz.

Source AC Level Test

This test measures the source AC output from maximum to minimum by using the attenuator to vary the source level.

Hardware connections: Analyzer's source output to the DVM's input using a BNC cable and a BNC to banana jack adapter.

Initial DVM settings: Default with AC voltage measurement selected.

Initial analyzer settings:

View Menu: All toolbars except Marker Functions Toolbar selected. The Extended Functions Interface checked (enabled).

Sweep Control Toolbar: Sweep Mode in continuous mode, Sweep Type is Lin x and Points equal to 100

Sweep Frequency Toolbar: Center/Span mode selected, Center Frequency is 1.0 KHz, Span Frequency is 0 Hz.

Source Parameters Toolbar: Source On, Constant Source Level, Source Level is 1.77 volts, step size set to 1dB and DC offset is 0 V. High source level mode is disabled.

Using the Sweep Control Toolbar start the sweep and record the DVM's AC voltage.

Minimum Source AC level: 1.68 VRMS. Maximum Source AC level: 1.86 VRMS.

Select the DVM's dB relative mode. The DVM should read 0 dB +/-0.01 dB maximum deviation. Using the source decrement button on the Source Parameters Toolbar decrement the source level 1dB while recording the value. Repeat until source reads 1.25mV on the Source Parameters Toolbar. The limit is a 1 dB +/-1.0 dB maximum deviation for each attenuator step change.

Enable high source level mode and set the source level to the maximum value of 7.08 volts.

Select the DVM's to AC voltage mode and record the DVM's AC voltage. Minimum Source AC level: 6.73 VRMS. Maximum Source AC level: 7.43 VRMS.

Select the DVM's dB relative mode. The DVM should read 0 dB +/-0.01 dB maximum deviation. Using the source decrement button on the Source Parameters Toolbar decrement the source level 1dB while recording the value. Repeat until source reads 5mV on the Source Parameters Toolbar. The limit is a 1 dB +/-1.0 dB maximum deviation for each attenuator step change.

Using the Source decrement button on the Source Parameters Toolbar decrease the source level in 1 dB increments while recording the DVM's DC voltage at each step. Continue until the Source Level reaches the minimum value (5mV volts). Maximum Source DC (null) value: (+/-) 30mV DC.

Source DC Offset Test

This test measures the Source DC Output Offset from minimum to maximum.

Hardware connections: Analyzer's source output to the DVM's input using a BNC cable and a BNC to banana jack adapter.

Initial DVM settings: Default with DC voltage measurement selected.

Initial analyzer settings:

View Menu: All toolbars except Marker Functions Toolbar selected. The Extended Functions Interface checked (enabled).

Source Parameters Toolbar: Source On, Source Level is 1.25mV volts and Offset is 10.0 V. High source level mode is disabled.

Record the DVM's DC voltage. Minimum: 9.50 VDC. Maximum: 10.50 VDC.

Change the Offset entry in the Source Parameters Toolbar to -10.0 V (followed by a ENTER on the keyboard).

Record the DVM's DC voltage. Minimum Source DC level: -10.50 VDC. Maximum Source DC level: -9.50 VDC.

Source DC Null Test

This test measures the source DC null value which is the undesired DC component of the AC source signal.

Hardware connections: Analyzer's source output to the DVM's input using a BNC cable and a BNC to banana jack adapter.

Initial DVM settings: Default with DC voltage selected. NPLC (line cycle avg.) =10.

Initial analyzer settings:

View Menu: All toolbars except Marker Functions Toolbar selected. The Extended Functions Interface checked (enabled).

Sweep Control Toolbar: Sweep Mode in continuous mode, Sweep Type is Lin x and Points equal to 100

Sweep Frequency Toolbar: Center/Span mode selected, Center Frequency is 1.0 KHz, Span Frequency is 0 Hz.

Source Parameters Toolbar: Source On, Constant Source Level, Source Level is 1.77 volts, step size set to 1dB and DC offset is 0 V. High source level mode is disabled.

Receiver Parameters Toolbar: Bandwidth set to 10Hz.

Using the Sweep Control Toolbar start the sweep. Using the Source decrement button on the Source Parameters Toolbar decrease the source level in 1 dB increments while recording the DVM's DC voltage at each step. Continue until the Source Level reaches the minimum value (1.25mV volts). Maximum Source DC (null) value: (+/-) 30mV DC.

Enable high source level mode and set the source level to the maximum value of 7.08 volts. Using the Source decrement button on the Source Parameters Toolbar decrease the source level in 1 dB increments while recording the DVM's DC voltage at each step. Continue until the Source Level reaches the minimum value (5mV volts). Maximum Source DC (null) value: (+/-) 30mV DC.

Receiver Dynamic Range Test

This test measures the dynamic range of each receiver channel.

Hardware connections: Analyzer's source output connected to the receiver's input channel A using the 12 inch BNC cable. On the receiver's input channel B use the 50 Ohm BNC termination.

Initial analyzer settings:

View Menu: All toolbars except Marker Functions Toolbar selected. The Extended Functions Interface unchecked (disabled).

Graph Menu: Magnitude and Phase selected.

Sweep Control Toolbar: Sweep Mode in continuous mode, Sweep Type is Log x and Points equal to 200.

Sweep Frequency Toolbar: Start/Stop mode selected, Start Frequency is 10 Hz, Stop Frequency is 30 MHz.

Source Parameters Toolbar: Source On and Source Level set to 1.58 volts. High source level mode is disabled.

Receiver Parameters Toolbar: AC Coupling active and Bandwidth set to 10 Hz.

Graph Tools Toolbar: Markers enabled.

Using the Sweep Control Toolbar start the sweep. After a full sweep has been completed use the Graph Tools Toolbar to activate the autoscale button. The observed Magnitude data should be within the following limits up to 5 MHz; Maximum magnitude: -100 dB. No minimum magnitude. From 5 MHz to 30 MHz: Maximum magnitude: -90 dB. No minimum magnitude. Additionally, perform the next test by connecting the analyzer's source output to the receiver's input channel B using the 12 inch BNC cable. On the receiver's input channel A use the 50 Ohm BNC termination. Using the Sweep Control Toolbar stop and then restart the sweep. After a full sweep has been completed use the Graph Tools Toolbar to activate the autoscale button. The observed Magnitude data should be within the following limits up to 5 MHz; Minimum magnitude: 100 dB. No maximum magnitude. From 5 MHz to 30 MHz: Minimum magnitude: 90 dB. No maximum magnitude.

Receiver Magnitude and Phase (Through-line) Test

This test gives measures the analyzer's receiver accuracy using a through-line (0 dB attenuator).

Hardware connections: Analyzer receiver's input channels A and B connected to the source through a BNC Tee connector and two identical 12 inch BNC cables.

Initial analyzer settings:

View Menu: All toolbars except Marker Functions Toolbar selected. The Extended Functions Interface unchecked (disabled).

Graph Menu: Magnitude and Phase selected.

Sweep Control Toolbar: Sweep Mode in continuous mode, Sweep Type is Log x and Points equal to 100

Sweep Frequency Toolbar: Start/Stop mode selected, Start Frequency is 10 Hz, Stop Frequency is 30 MHz.

Source Parameters Toolbar: Source On and Source Level is 1.25 Volts. High source level mode is disabled.

Receiver Parameters Toolbar: AC Coupling active and Bandwidth set to 10 Hz.

Graph Tools Toolbar: Markers enabled.

Using the Sweep Control Toolbar start the sweep. After a full sweep has been completed use the Graph Tools Toolbar to activate the autoscale button.

The Magnitude and Phase data should be within the following limits up to 1 MHz;
Magnitude: 0 dB \pm 0.025 dB maximum deviation. Phase: 0 Degree \pm 0.2 Degree maximum deviation. From 1 MHz to 30 MHz the Magnitude and Phase data should be within the following limits: Magnitude: 0 dB \pm 0.05 dB maximum deviation. Phase: 0 Degree \pm 0.8 Degree maximum deviation.

Receiver Magnitude (Attenuator) Test

This test gives measures the analyzer's receiver accuracy using 20, 40, 60 and 80 dB attenuators.

Hardware connections: The receiver's input channel B connected to the source through a BNC Tee connector and a 12 inch BNC cable. The attenuator's input is connected to the source through the remaining BNC Tee connector using a 12 inch BNC cable. The receiver's input channel A is connected to the selected attenuator's output.

Initial analyzer settings:

View Menu: All toolbars except Marker Functions Toolbar selected. The Extended Functions Interface unchecked (disabled).

Graph Menu: Magnitude and Phase selected.

Sweep Control Toolbar: Sweep Mode in continuous mode, Sweep Type is Log x and Points equal to 100

Sweep Frequency Toolbar: Start/Stop mode selected, Start Frequency is 100 Hz, Stop Frequency is 1 MHz.

Source Parameters Toolbar: Source On and Source Level set to 1.58 Volts. High source level mode is disabled.

Receiver Parameters Toolbar: AC Coupling active and Bandwidth set to 10 Hz.

Graph Tools Toolbar: Markers enabled. Place marker 1 at 1KHz and marker 2 at 100KHz.

Select the first (20dB) attenuator and connect as instructed above.

Use the Sweep Control Toolbar to start the sweep. After a full sweep has been completed record the magnitude data at the marker frequencies. To obtain the negative dB values connect the attenuator output to receiver channel B while connecting channel A to the Tee connector at the source. Use the Sweep Control Toolbar to stop then restart the sweep. After a full sweep has been completed record the magnitude data at the marker frequencies. Repeat

the measurement procedure using the remaining attenuators. The table below gives the magnitude limits for each attenuator value.

Attenuation Test	Minimum dB	Maximum dB
+20 dB	19.975	20.025
-20 dB	-20.025	-19.975
+40 dB	39.965	40.035
-40 dB	-40.035	-39.965
+60 dB	59.7	60.3
-60 dB	-60.3	-59.7
+80 dB	78.5	81.5
-80 dB	-81.5	-78.5

Receiver Absolute Magnitude Test

This test gives measures the analyzer's receiver accuracy for Absolute Magnitude Voltage. Step one, measure the source level at 1KHz and 100KHz as follows:

Initial hardware connections: Analyzer's source output to the DVM's input using a BNC cable and a BNC to banana jack adapter.

Initial DVM settings: Default with AC voltage measurement selected.

Initial analyzer settings:

View Menu: All toolbars except Marker Functions Toolbar selected. The Extended Functions Interface unchecked (disabled).

Graph Menu: Absolute Magnitude selected.

Sweep Control Toolbar: Sweep Mode in continuous mode, Sweep Type is Lin x and Points equal to 100

Sweep Frequency Toolbar: Center/Span mode selected, Center Frequency is 1.0 KHz, Span Frequency is 0 Hz.

Source Parameters Toolbar: Source On, Source Level is 1.0 volts. High source level mode is disabled.

Receiver Parameters Toolbar: AC Coupling active and Bandwidth set to 10 Hz.

Using the Sweep Control Toolbar start the sweep and record the DVM's AC voltage.

Appendix H: System Calibration / Performance Verification

Using the Sweep Frequency Toolbar change the Center Frequency to 100 KHz and record the DVM's AC voltage.

Using the Sweep Control Toolbar stop the sweep.

Step two, use the receiver channels to measure the source at 1KHz and 100KHz as follows:

Hardware connections: Analyzer's source output connected to the receiver's input channels A and B using two identical 12 inch BNC cables connected to the source through a BNC Tee connector.

Additional analyzer settings:

Sweep Control Toolbar: Sweep Mode in continuous mode, Sweep Type is Log x and Points equal to 100

Sweep Frequency Toolbar: Start/Stop mode selected, Start Frequency is 100 Hz, Stop Frequency is 1 MHz.

Graph Tools Toolbar: Markers enabled. Place marker 1 at 1KHz and marker 2 at 100KHz.

Use the Sweep Control Toolbar to start the sweep. After a full sweep has been completed record the absolute magnitude data at the marker frequencies for channels A and B. The data should read within +/-2% of the voltage measured by the DVM

INDEX

A	
Appendices	87
Appendix A: Theory of Operation	87
Appendix B: Measurement Accuracy	88
Appendix C: Specifications.....	92
Appendix D: File Types, Use and Format	95
Appendix E: Default Setup Values....	98
Appendix F: Repair and Warranty Information.....	100
Appendix G: Source Fuse Replacement	102
Appendix H: System Calibration	103
Application Notes	
Basic Measurement Procedures.....	73
Circuits with Nonzero DC Voltage Levels at the Inp	76
High Frequency Measurements.....	75
Introduction to Analog Network Measurements.....	71
Line Current Harmonic Measurements	83
Measuring Circuits with High Common Mode Voltages	76
Measuring Complex Impedance.....	81
Measuring Feedback Loop Frequency Response.....	77
Power Transmission/Reflection Measurements.....	84
C	
Calibration, Probe.....	26, 38
D	
Data Files.....	53, 95
Data Transfer	
Data Files	53
Dynamic Data Exchange (DDE).....	56
Image Files.....	54
The Clipboard (bitmap data).....	55
The Clipboard (text data).....	55
Data Window	17
Markers	18
Dynamic Data Exchange (DDE).....	56
Data Links.....	57
Execute Commands	61
How a DDE Link is Established.....	56
The Analyzer Software	57
The DDE Client	56
Using DDE in Microsoft Excel.....	64
E	
Edit Menu	22
Copy Bitmap	22
Copy Data	22
Copy Master Data	22
Paste Data to Master	22
Extended Functions Interface	11
F	
File Menu.....	20
Exit.....	21
Open Data	20
Open Setup.....	20
Print Display Mode Setup.....	21
Print Graph.....	21
Print Preview	21
Printer Setup	21
Save Data	21
Save Graph Image.....	21
Save Setup	20

Save Setup As	20
Frequency Point List (FPL) Files.....	97

G

Graph Display Modes	14
Absolute Magnitude.....	14
Complex Impedance	14
Magnitude and Phase	14
Graph Menu	25
Absolute Magnitude.....	25
Complex Impedance	25
Magnitude & Phase.....	25
Graph Tools Toolbar	
Auto Scale.....	49
Display Left Trace	50
Display Right Trace	50
Manual Scale.....	50
Markers	49
Master Trace	49
Reference Trace	49
UnZoom.....	50
Zoom.....	50
Graph Window.....	15
Master traces	16
Real-Time Traces.....	15
Reference traces	16
Zooming.....	16

I

Image Files.....	54
Installation	
Hardware.....	7
Host PC requirements	7
Software	9

M

Main Toolbar	
Copy Data	42
Help.....	42

New Setup	41
Open Setup	41
Print	42
Save Setup	42

Marker Functions Toolbar

Find Max, Min.....	52
Marker Active Selection Box	51
Marker Tracking.....	52
Markers Scroll Box.....	51
Reference to Marker	52
Search Absolute.....	51
Search Left Data, Right Data.....	51
Search Left of Marker, Right of Marker	52
Search Relative.....	51
Search Value Edit Box	52

Menu Selections

O

Offline Mode	12
Options	
Advanced.....	37
Colors	32
Data Columns	35
Data Format	34
Display.....	33
Trace Math	36

P

Probe Calibration.....	38
------------------------	----

R

Raw Data Files	96
Receiver Parameters Toolbar	
BW (Band Width).....	48
Coupling	48
Probe Cal 1,2	48

S		Graph Tools Toolbar.....	49
Source Parameters Toolbar		Main Toolbar	41
Constant Source Level.....	46	Marker Functions Toolbar	51
Level.....	47	Receiver Parameters Toolbar	48
Output.....	46	Source Parameters Toolbar	46
Source DC Offset	47	Sweep Control Toolbar.....	43
Variable Source Level.....	46	Sweep Frequency Toolbar	45
Sweep Control Toolbar		Tools Menu.....	26
Avg (Averaging)	44	Calibration	26
Pause Sweep.....	43	Complex Impedance	26
Points.....	44	Options.....	32
Start Sweep.....	43	Trace Summing.....	31
Stop Sweep.....	43	Variable Source.....	29
Sweep Mode.....	43	V	
Sweep Type	43	Variable Source.....	29
Y Axis Graphing Type	44	View Menu	23
Sweep Frequency Toolbar		Extended Functions Interface	24
Center/Span	45	Status Bar.....	24
File List	45	Toolbars	23
Start/Stop.....	45	Virtual Instrument Front Panel	13
T			
Toolbars.....	41		

- Safety Notices -

- **Do not defeat power cord safety ground feature. Plug in to a grounded (earthed) outlet.**
- **Line and Current Protection Fuses: For continued protection against fire, replace the line fuses and the current-protection fuses only with fuses of the specified type and rating.**
- **Do not use product in any manner not specified by the manufacturer.**
- **Do not install substitute parts or perform any unauthorized modification to the product.**
- **Return the product to AP Instruments for service and repair to ensure that safety features are maintained**
- **Protection Limits: To avoid instrument damage and the risk of electric shock, do not exceed any of the protection limits listed below:**
Applied maximum voltage and current limits to source output and receiver inputs are **+15V/50mA peak from source/receiver (BNC) ground**
Applied maximum voltage between source/receiver (BNC) ground and safety earth ground is **42V peak.**